

# 8733348COM 4 Drawer Wide Dresser

# Ameriwood HOME

Date of Purchase \_\_\_ / \_\_\_ / \_\_\_  
Lot Number:

B348733348COM0



THIS INSTRUCTION BOOKLET CONTAINS **IMPORTANT** SAFETY INFORMATION. PLEASE READ AND KEEP FOR FUTURE REFERENCE.

### Do Not Return This Product!

Contact our customer service team for help first.

**Call:** 1-800-489-3351 (toll free)

Monday-Friday 9am - 5pm CST

**Visit:** [www.ameriwoodhome.com](http://www.ameriwoodhome.com)



## **WARNING**

- Unit can tip over causing severe injury or death.
- Anchor unit to stud in wall (if instructed to).
- Do Not allow children to climb on unit.
- Put heavy items on lower shelves or drawers.



Follow Ameriwood Home



## Contact Us!

### Do NOT return this product!

Contact our friendly customer service team first for help.

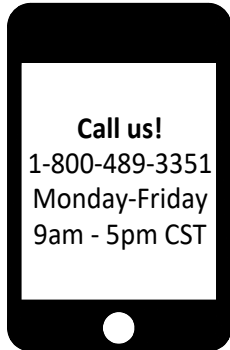

Visit [ameriwoodhome.com](http://ameriwoodhome.com) to view the limited warranty valid in the U.S. and Canada.

Assembly Tips



## Helpful Hints

PEOPLE NEEDED FOR ASSEMBLY: 2

ESTIMATED ASSEMBLY TIME: 1 HOUR

- Open your item in the area you plan to keep it to avoid excessive heavy lifting.
- Identify, sort and count the parts before attempting assembly.
- Compression dowels are lightly tapped in with a hammer.
- Slides are labeled with a **R** (right) and **L** (left) for proper placement.
- Make sure to always face the point on the top of the Cam Lock towards the outer edge.
- Use all the nails provided for the back panel and spread them out equally.
- Back panel must be used to make sure your unit is sturdy.
- Do NOT use harsh chemicals or abrasive cleaners on this item.
- Never push, pull, or drag your furniture.



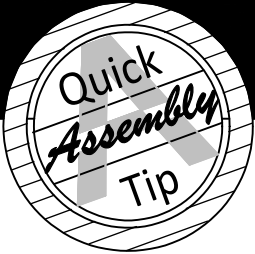

## Before You Start

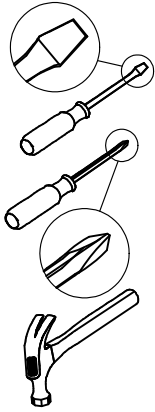

- ✓ Read through each step carefully and follow the proper order
- ✓ Separate and count all your parts and hardware
- ✓ Give yourself enough room for the assembly process
- ✓ Have the following tools: Flat Head Screwdriver, #2 Phillips Head Screwdriver and Hammer
- ✓ Caution: If using a power drill or power screwdriver for screwing, please be aware to slow down and stop when screw is tight. Failure to do so may result in stripping the screw.

## Cam Lock Fastening System

This Cam Lock Fastening System will be used throughout the assembly process.

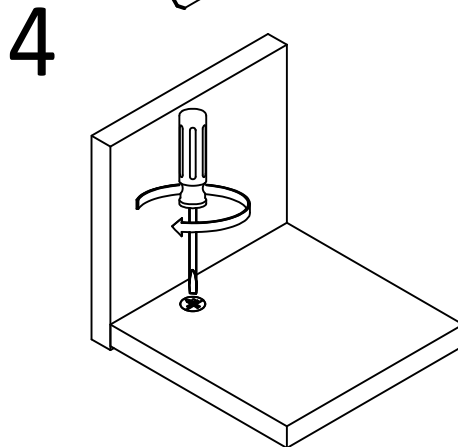
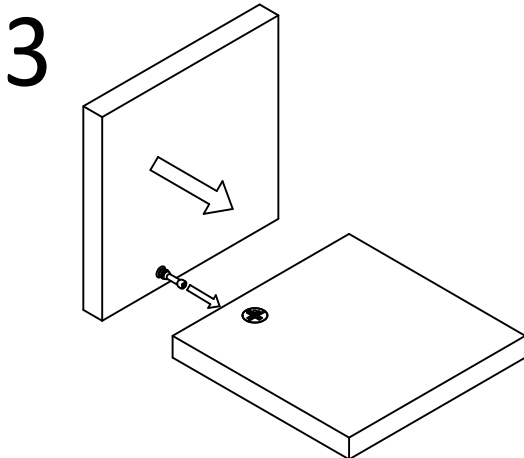
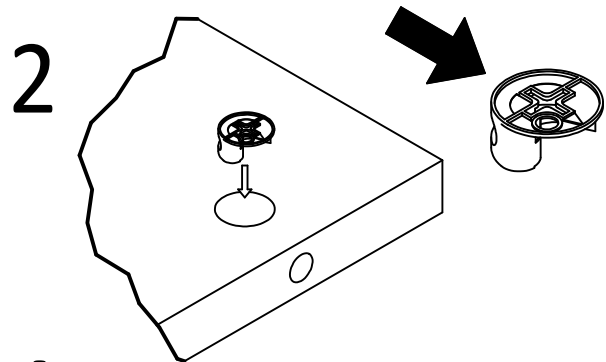
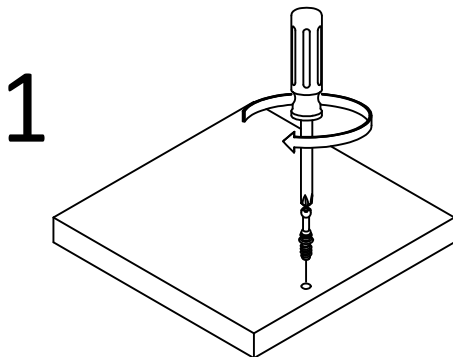

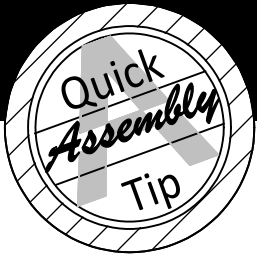

## Before You Start

Please Note:

You may need to lightly tap the wood dowels into the holes during your assembly process.

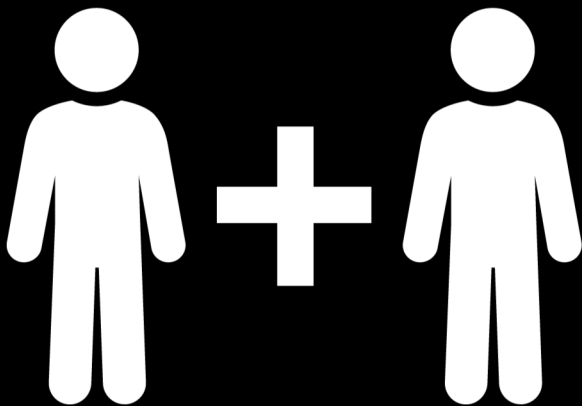
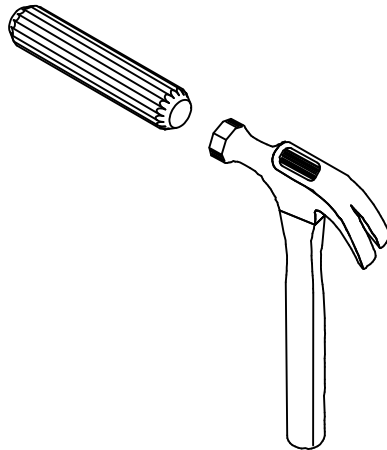

**2 PEOPLE NEEDED FOR ASSEMBLY**

**2 PERSONAS NECESITADAS  
PARA LA ASAMBLEA**

**2 PERSONNES NÉCESSAIRES  
POUR L'ASSEMBLAGE**

**CAUTION:** Failure to use 2 people for assembly could result in unit damage or personal injury.

**PRECAUCIÓN:** Si no se utilizan 2 personas para el ensamblaje, se pueden producir daños en la unidad o lesiones personales.

**ATTENTION:** Échec d'utiliser 2 personnes pour l'assemblage peut causer du dommage au meuble ou causer des blessures.

# Board Identification

Not actual size

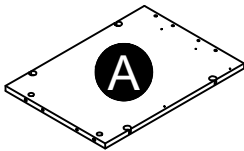

Left Panel  
38733348010

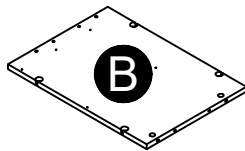

Right Panel  
38733348020

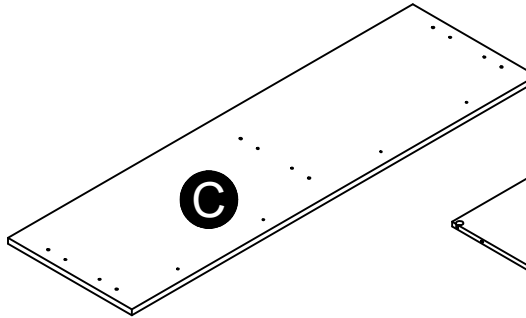

Top  
38733348030

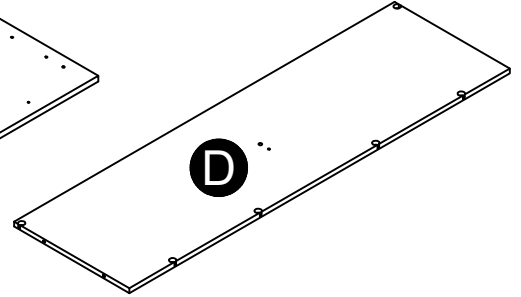

Bottom  
38733348040

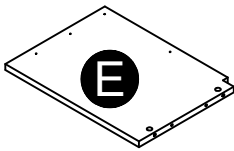

Partition  
38733348050

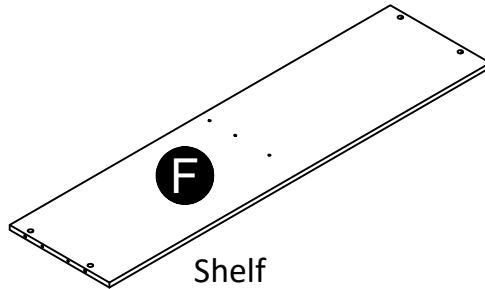

Shelf  
38733348060

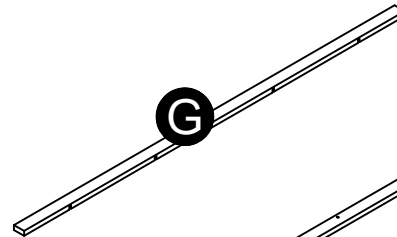

Top Rail  
38733348070

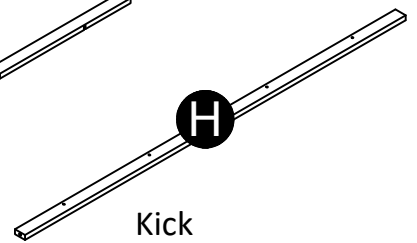

Kick  
38733348080

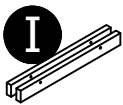

Side Kick (x2)  
38733348090

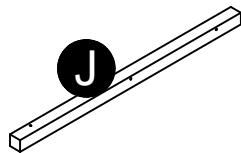

Left Front Leg  
38733348100

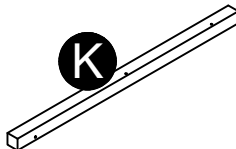

Right Front Leg  
38733348110

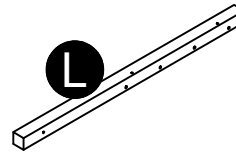

Left Rear Leg  
38733348120

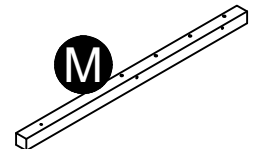

Right Rear Leg  
38733348130

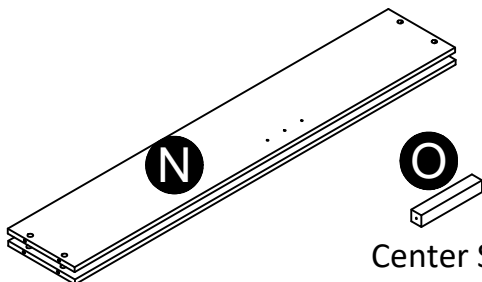

Solid Back (x2)  
38733000140

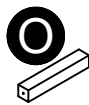

Center Support  
38733348150

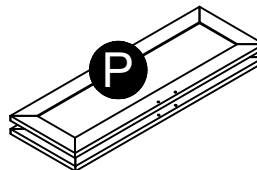

Left Drawer Front (x2)  
38733348160

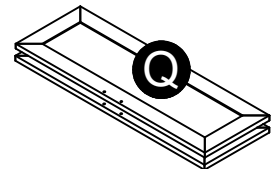

Right Drawer Front (x2)  
38733348170

# Board Identification

Not actual size



Left Drawer Side (x4)  
39991167346410L



Right Drawer Side (x4)  
39991167346410R

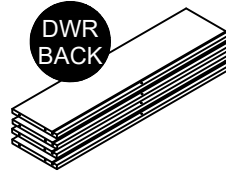

Drawer Back (x4)  
39991167065118B

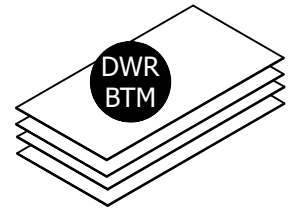

Drawer Bottom  
39991338066210D

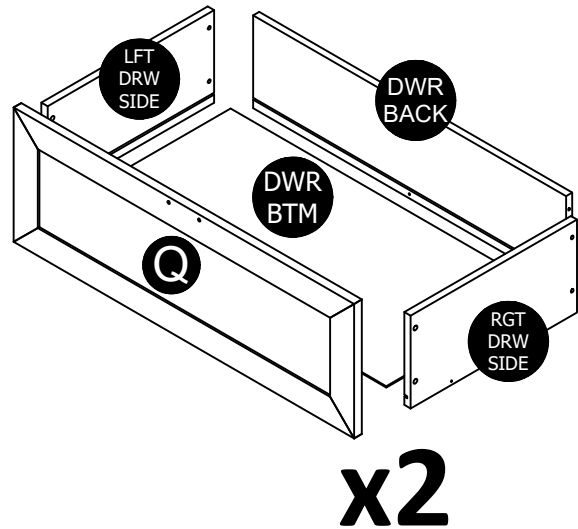
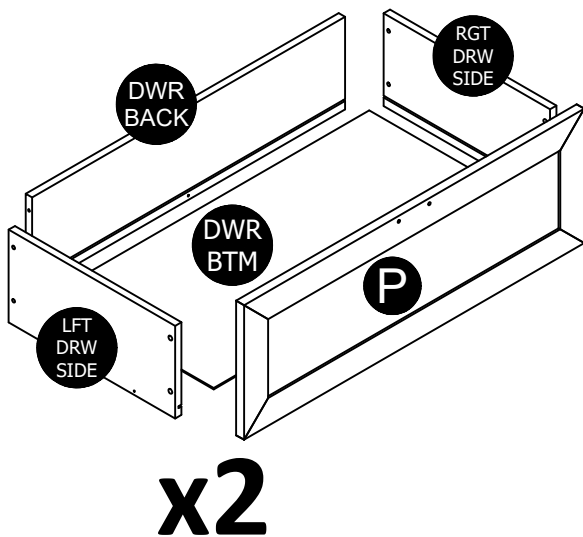

# Board Identification

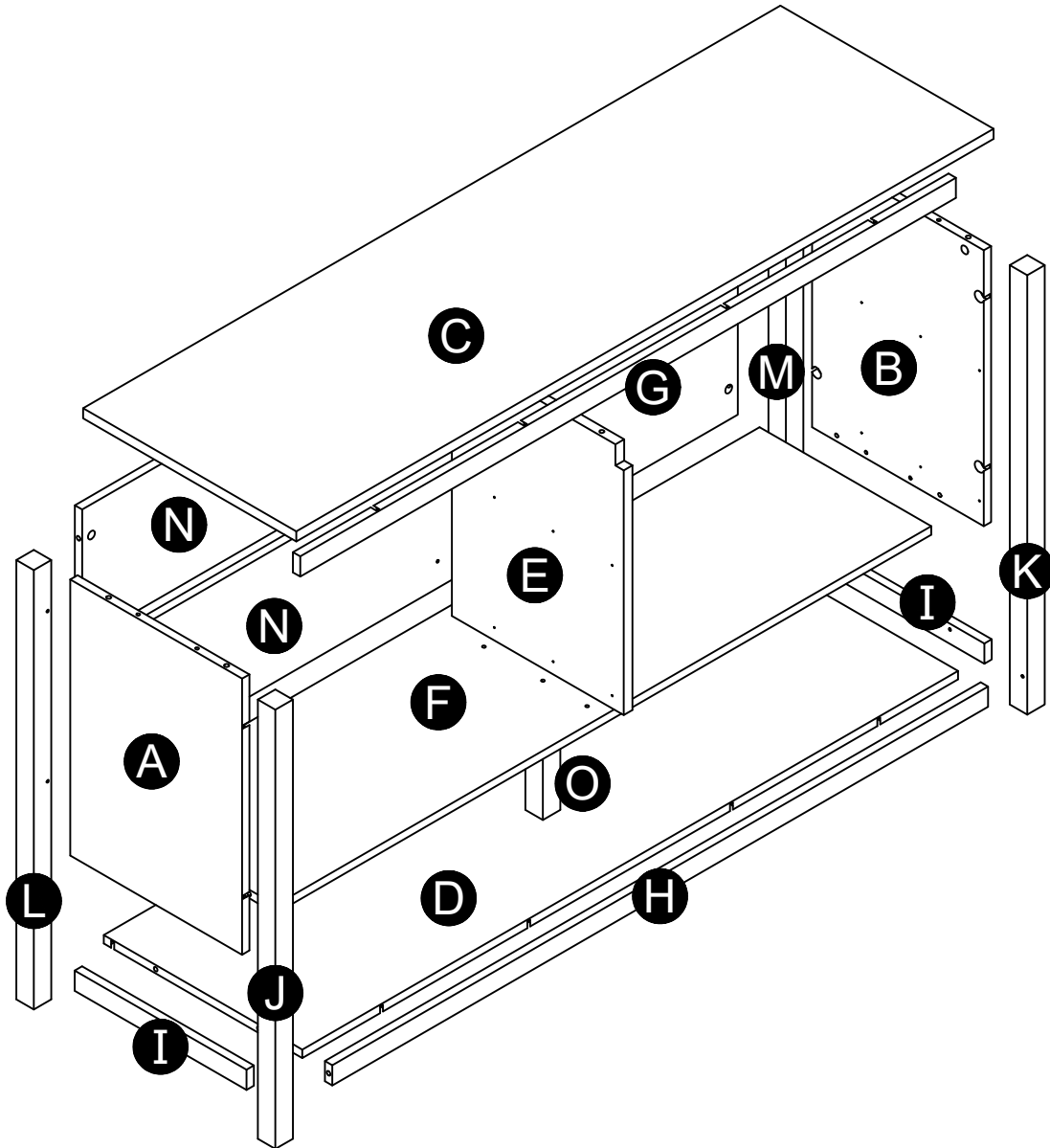

# Part List

## Actual Size

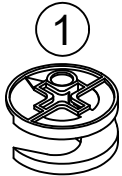

(x18)  
#A22620  
cam lock

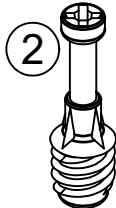

(x18)  
#A22610  
cam bolt

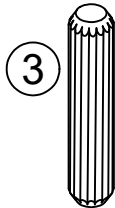

(x10)  
#A21670  
wood dowel

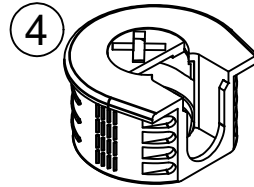

(x18)  
#A22920  
connector



(x18)  
#A22910  
connector bolt

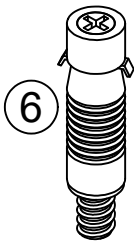

(x6)  
#A21960  
hidden fastener



(x40)  
#A11080  
7/16" screw

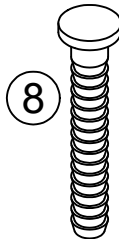

(x16)  
#A21975  
drive fastener



(x40)  
#A12120  
7/16" screw

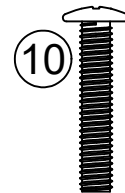

(x8)  
#A17400  
7/8" bolt

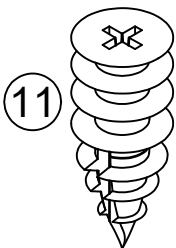

(x1)  
#A20940  
wall anchor

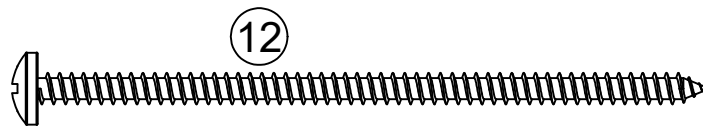

(x1)  
#A13950  
3-1/2" screw

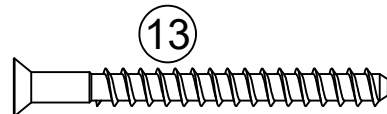

(x4)  
#A23030  
confirmat



# Part List

Not Actual Size

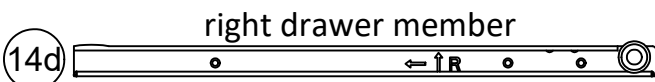
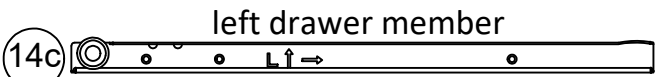
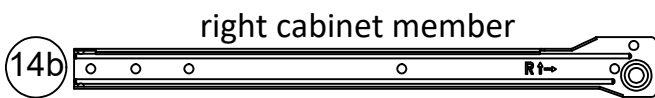
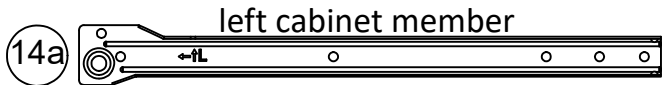

(x4)  
14 #A56770  
slide

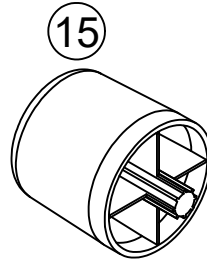

(x1)  
#A43105  
plastic foot

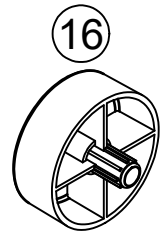

(x1)  
#A43490  
plastic spacer

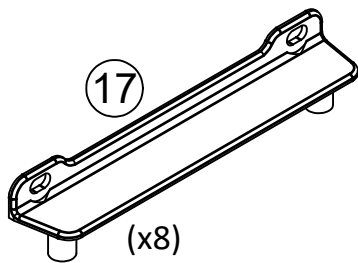

(x8)  
#A54520  
drawer bracket

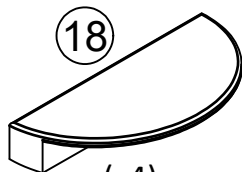

(x4)  
#A50160  
handle

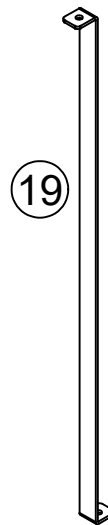

(x4)  
#A54900  
drawer brace

# STEP 1

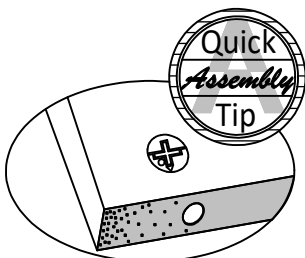
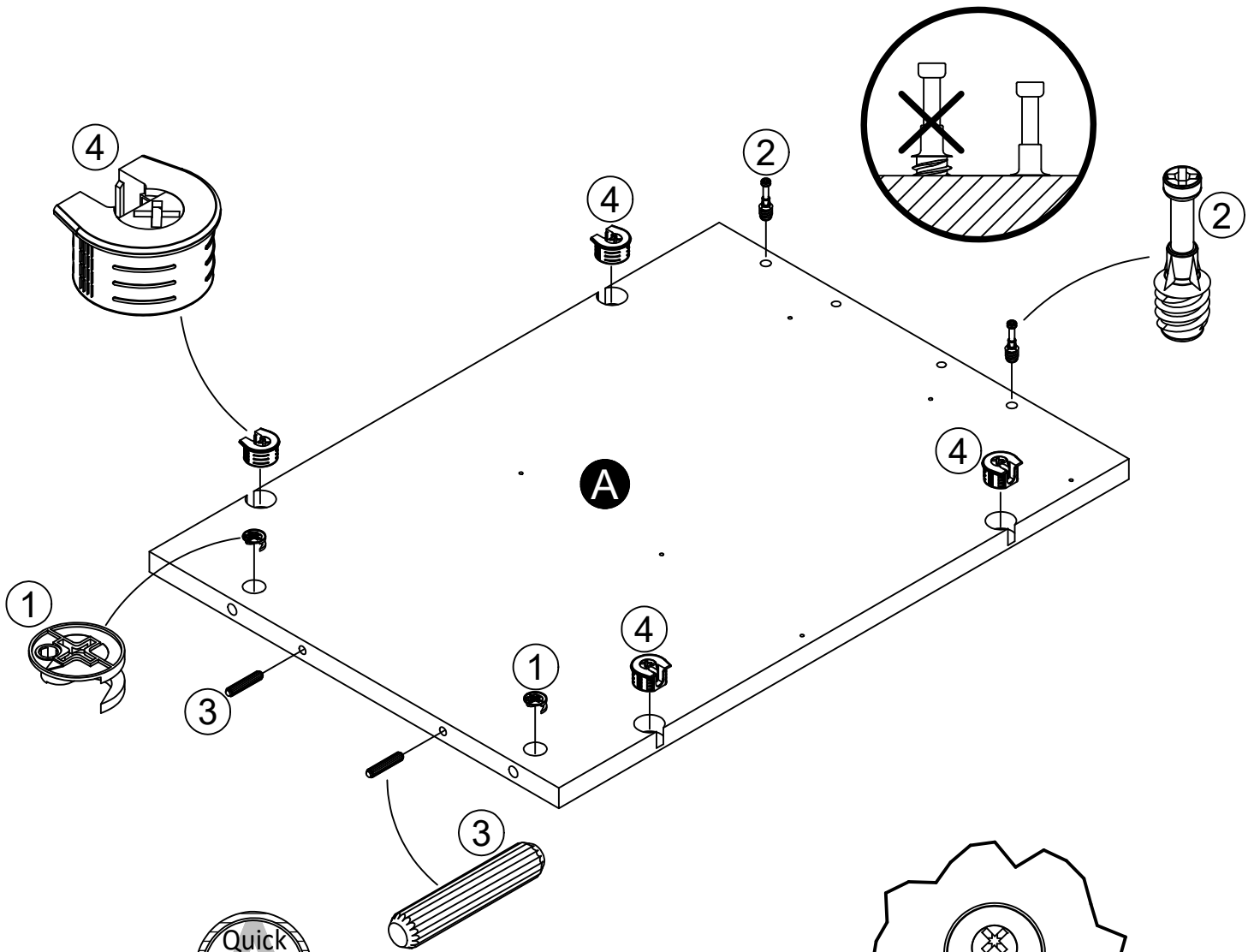
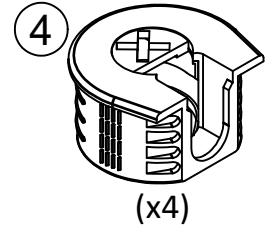
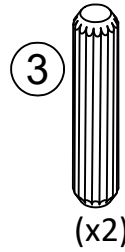
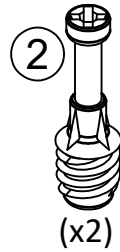
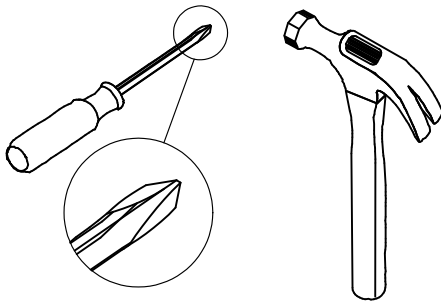

Proper orientation of CAM LOCK

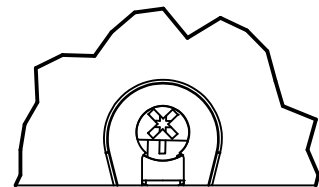

Be sure connector (4) is positioned as shown before inserting into hole. Tap with a hammer to fully insert.

## STEP 2

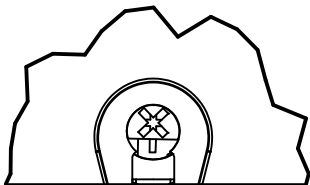
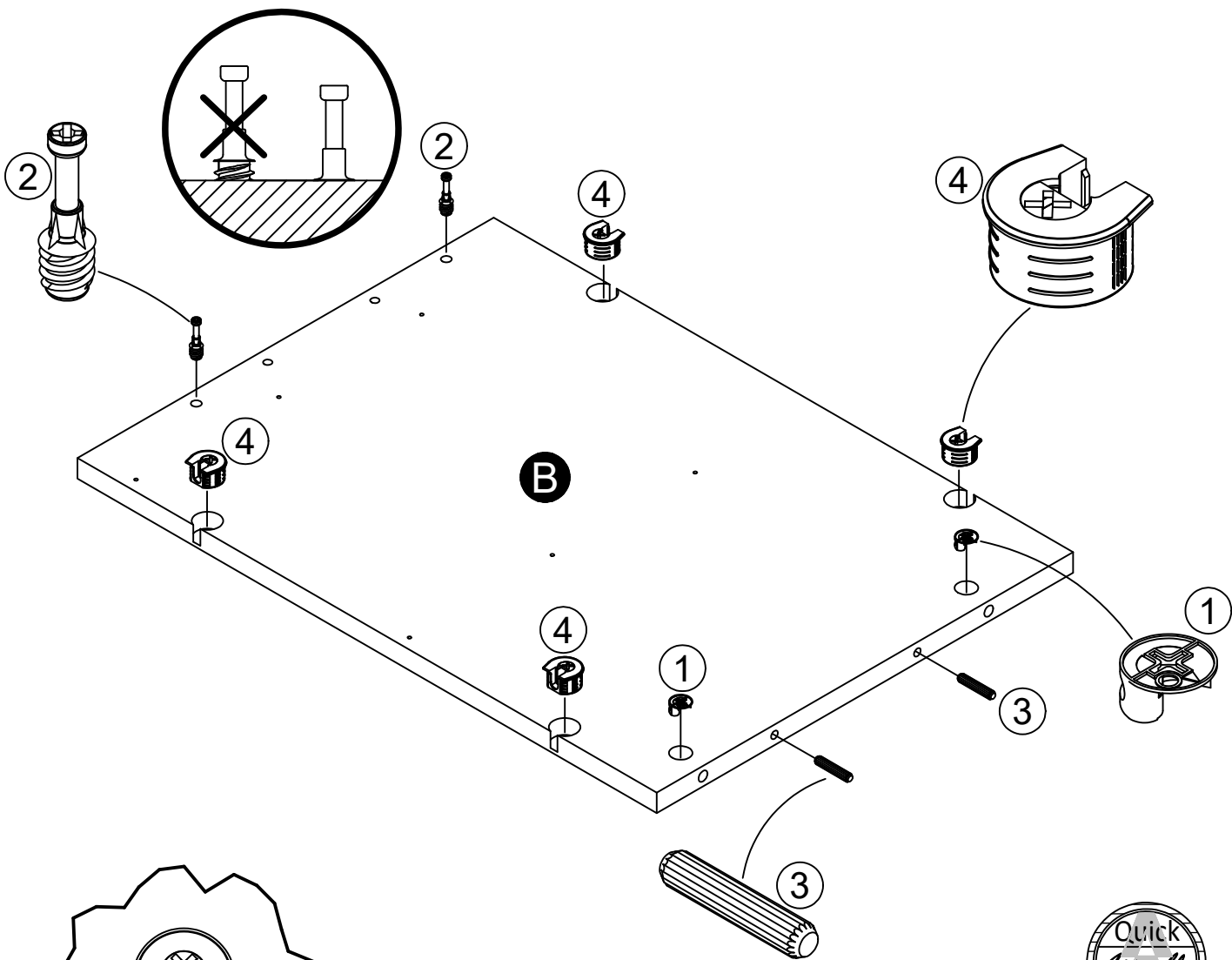
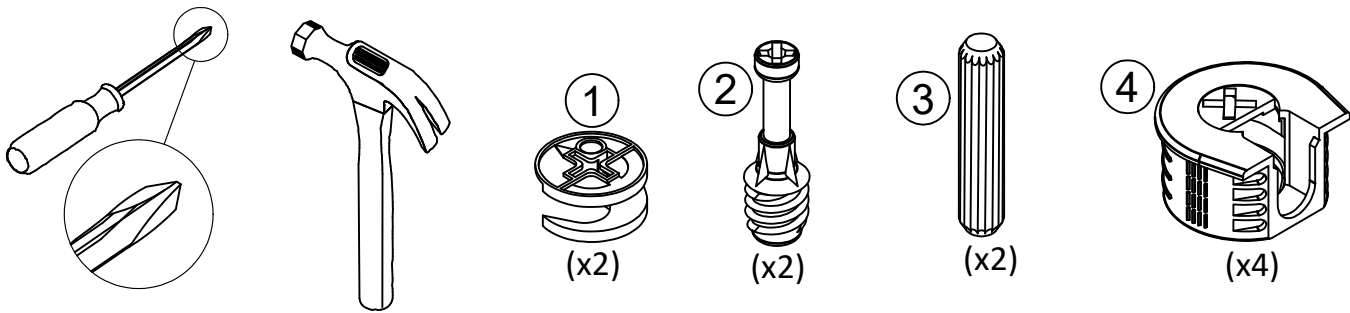

Be sure connector (4) is positioned as shown before inserting into hole. Tap with a hammer to fully insert.

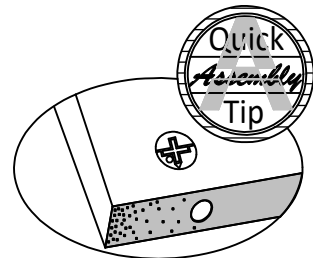

Proper orientation of CAM LOCK

## STEP 3

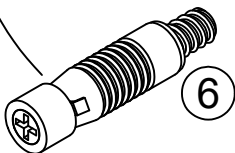
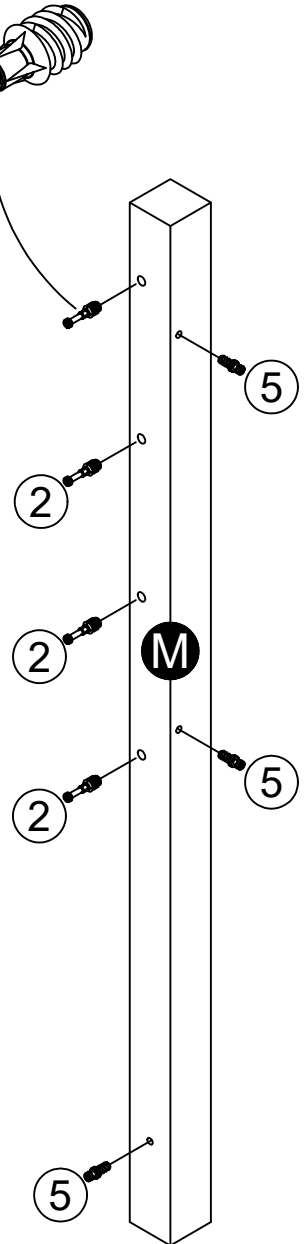
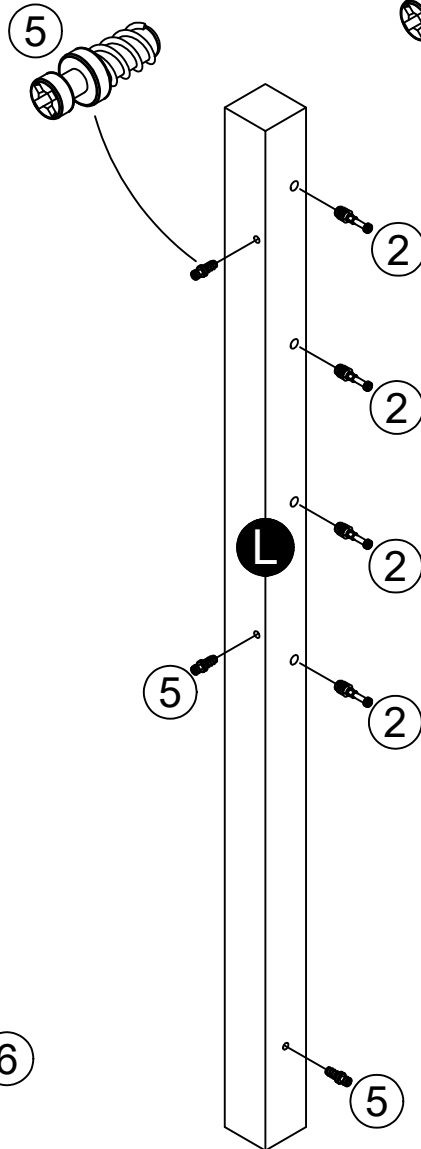
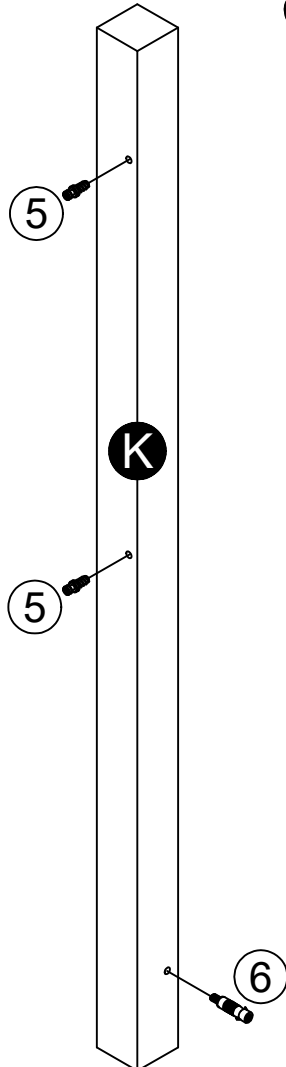
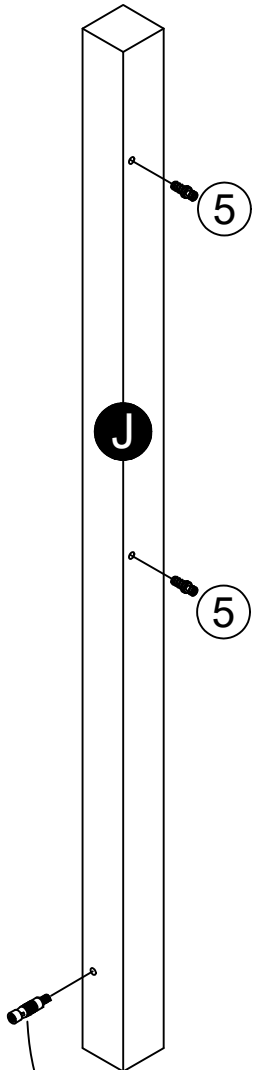
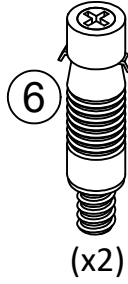
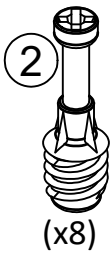
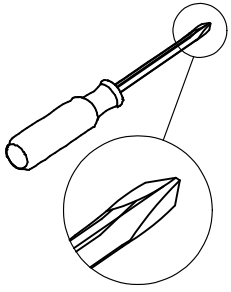

## STEP 4

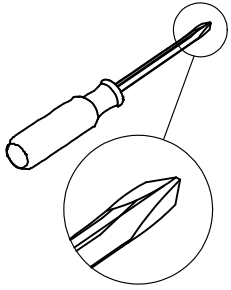

To attach left front leg (J) and left rear leg (L), position as show. Press down so connector bolts in legs engage with connectors (4). Turn connector (4) screw clockwise to lock in place.

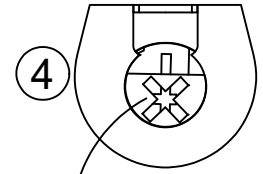

Turn clockwise to lock in place.

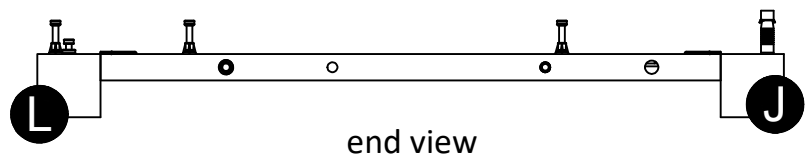
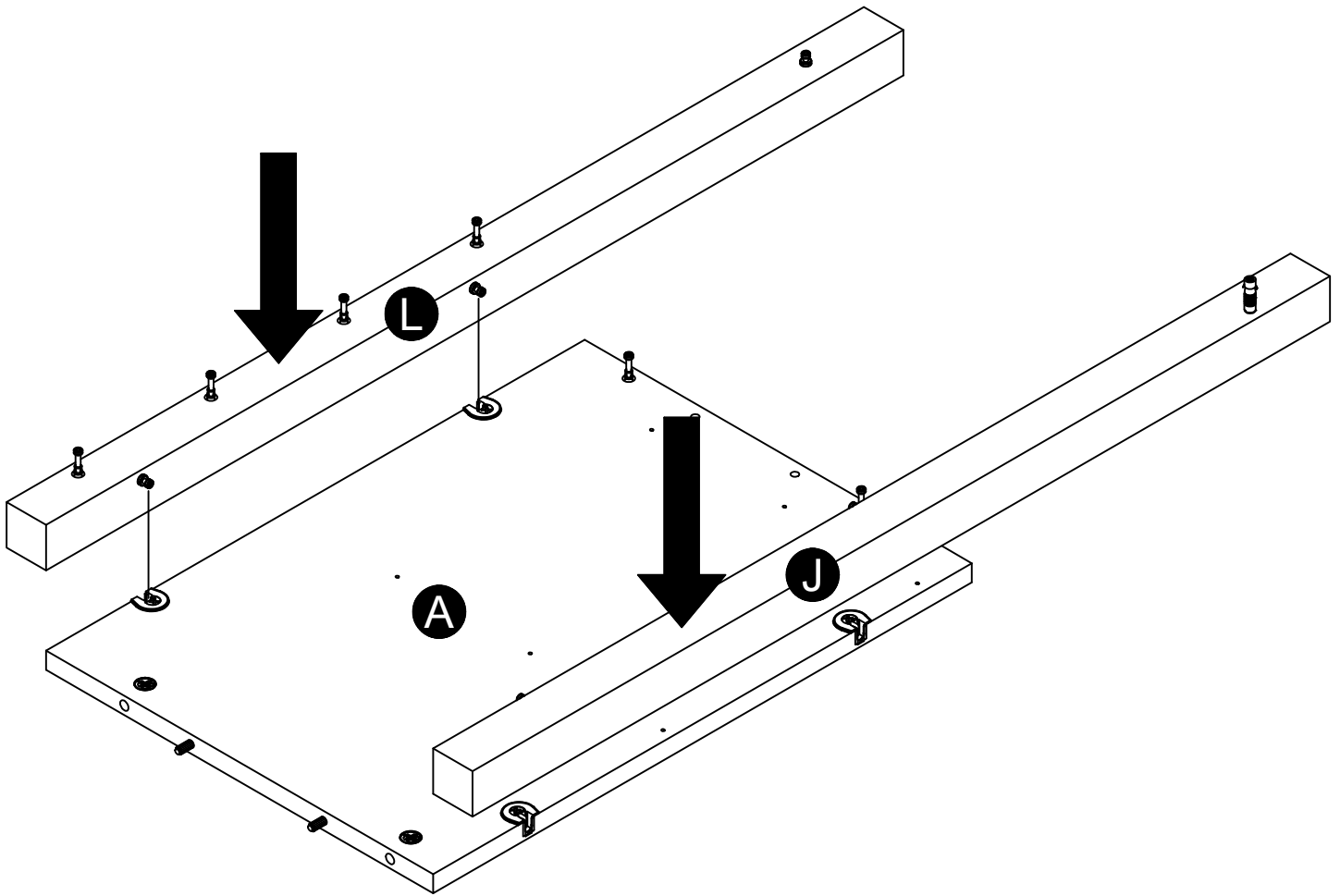

## STEP 5

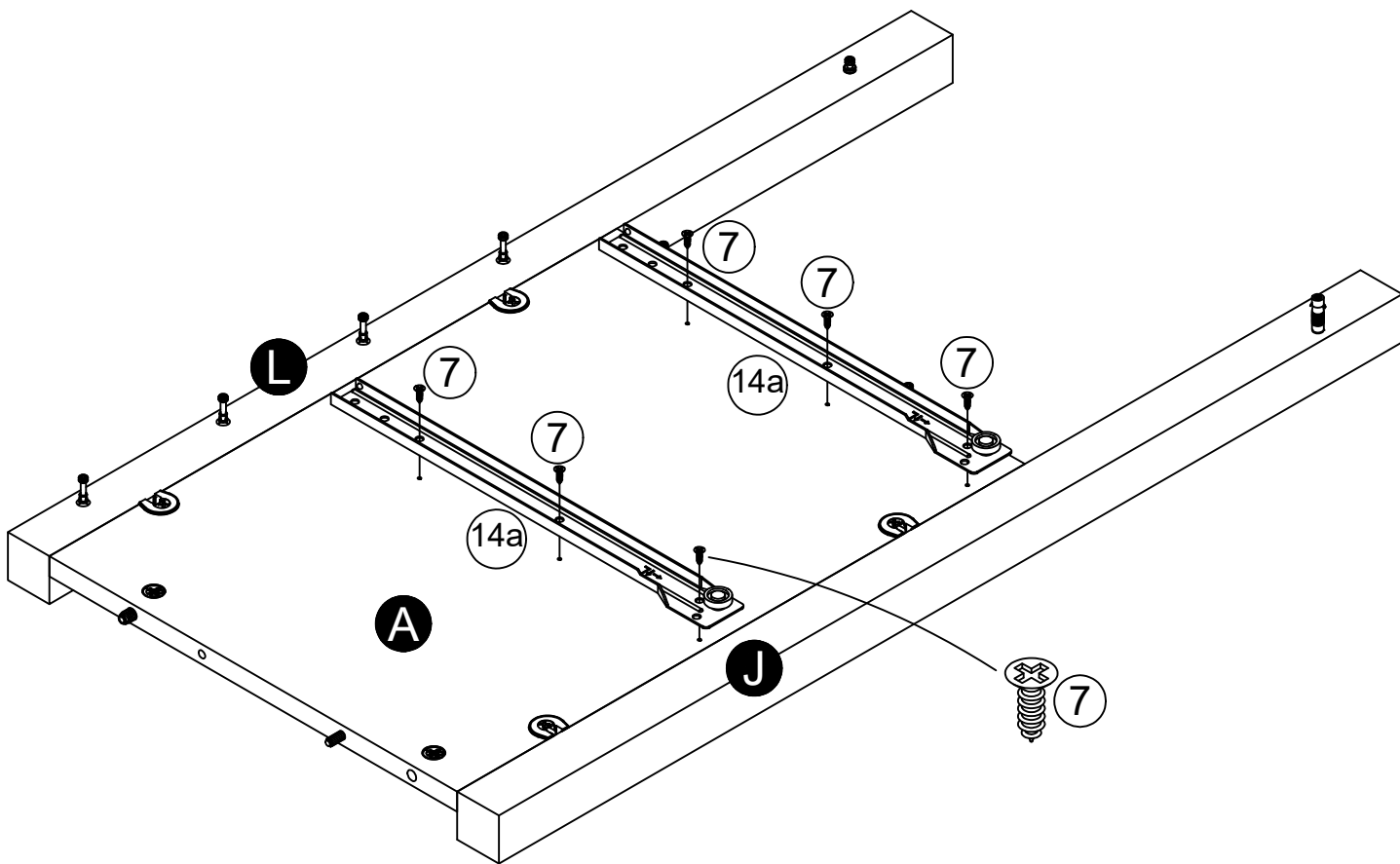
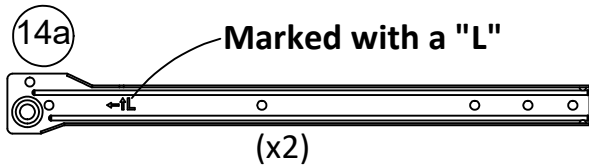
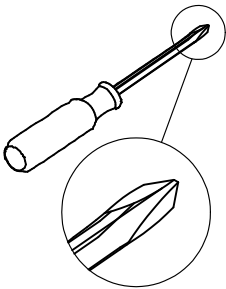

## STEP 6

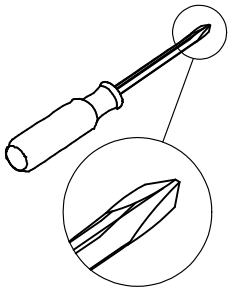

To attach right front leg (K) and right rear leg (M), position as show. Press down so connector bolts in legs engage with connectors (4). Turn connector (4) screw clockwise to lock in place.

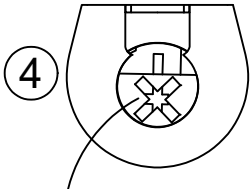

Turn clockwise to lock in place.

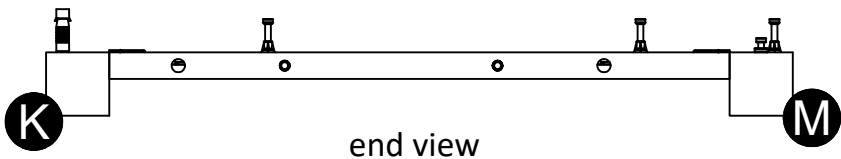
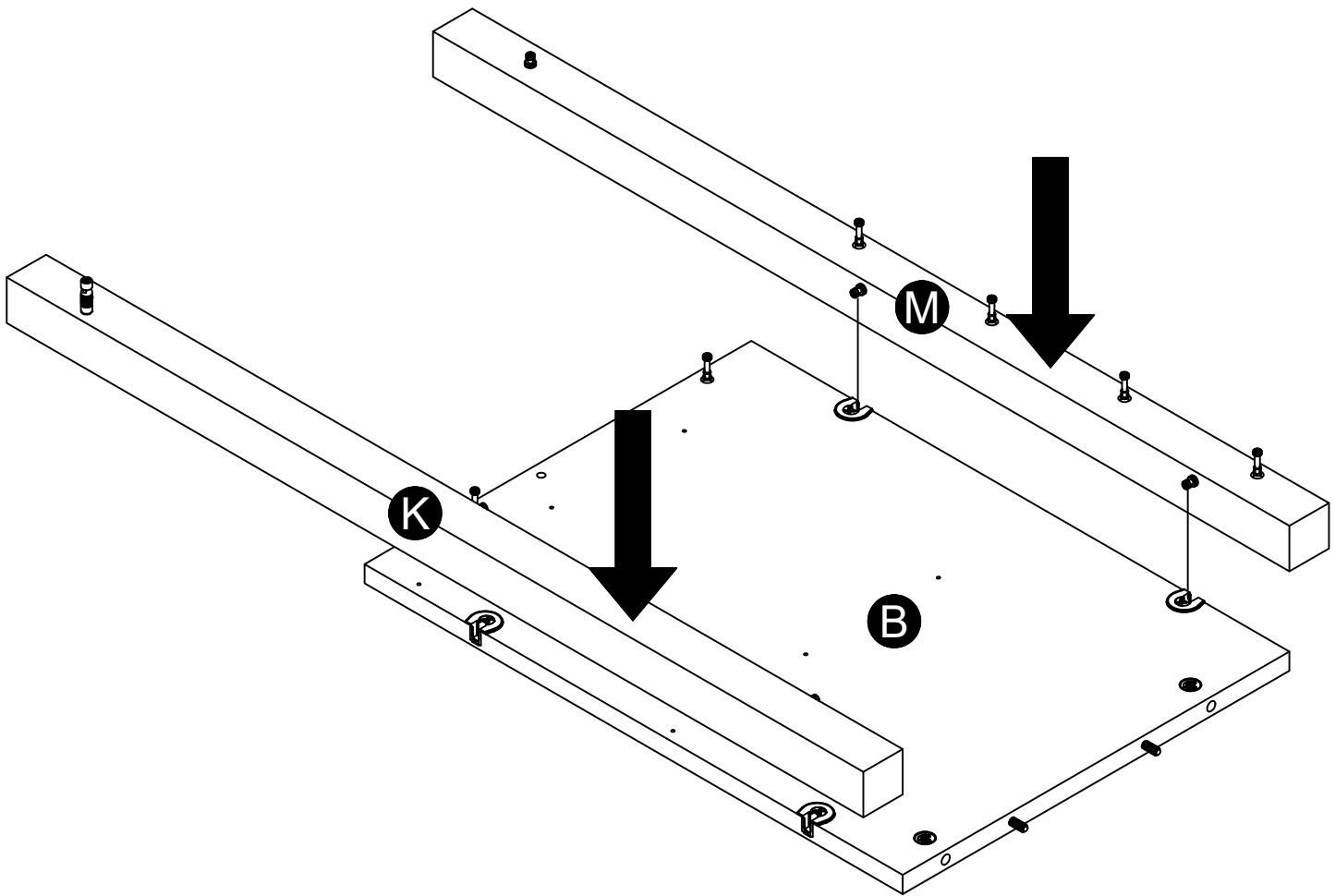

# STEP 7

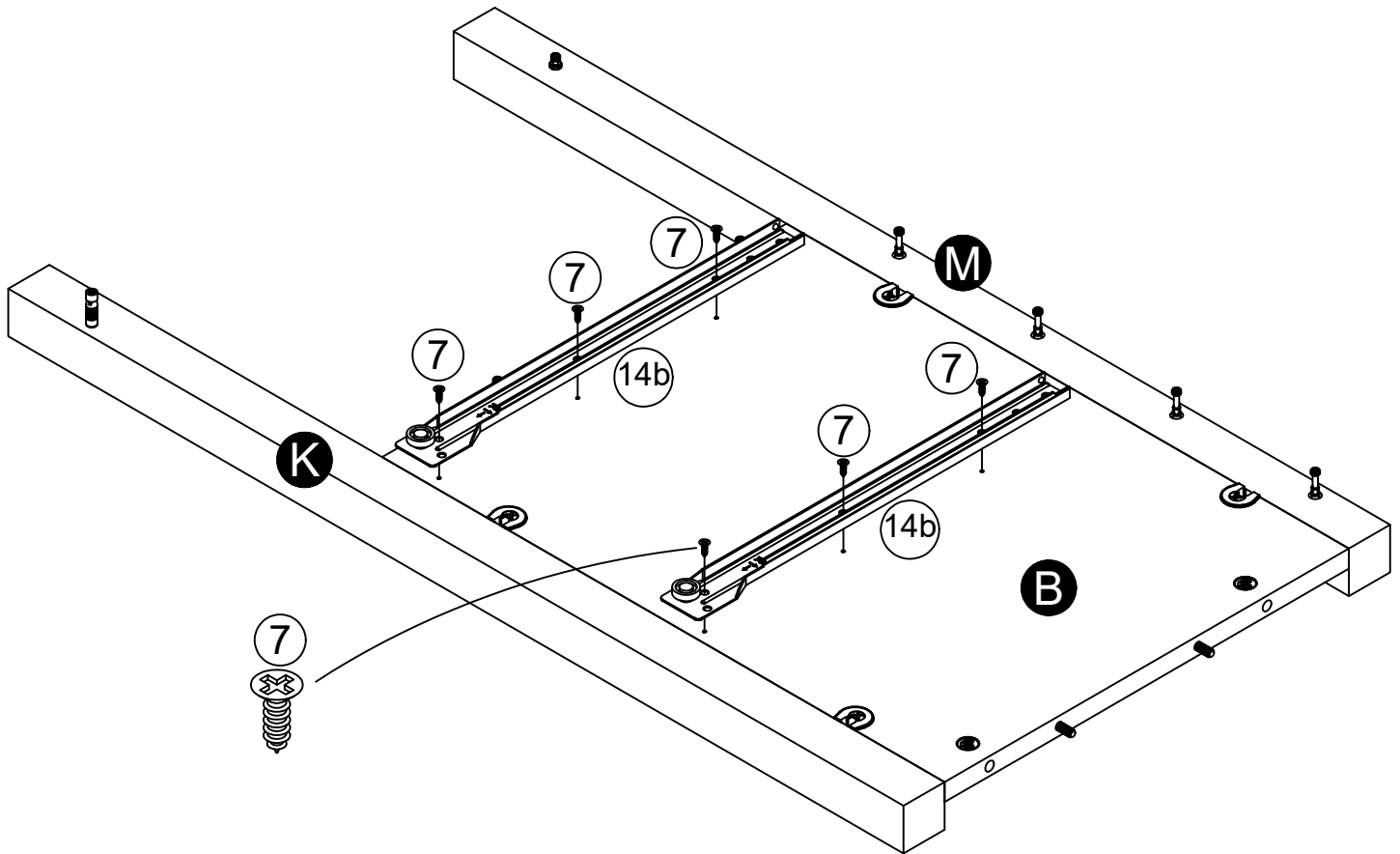
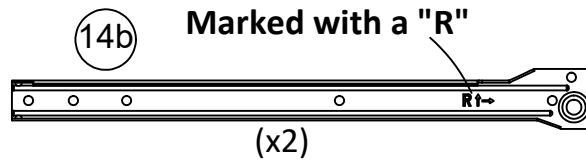
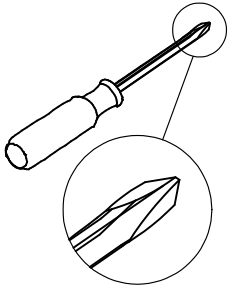



# STEP 8

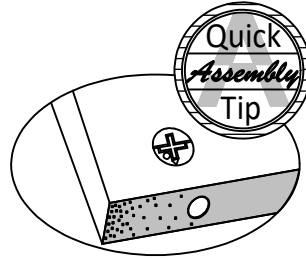
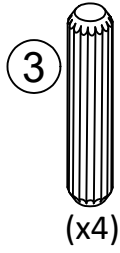
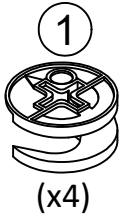

Proper orientation of CAM LOCK

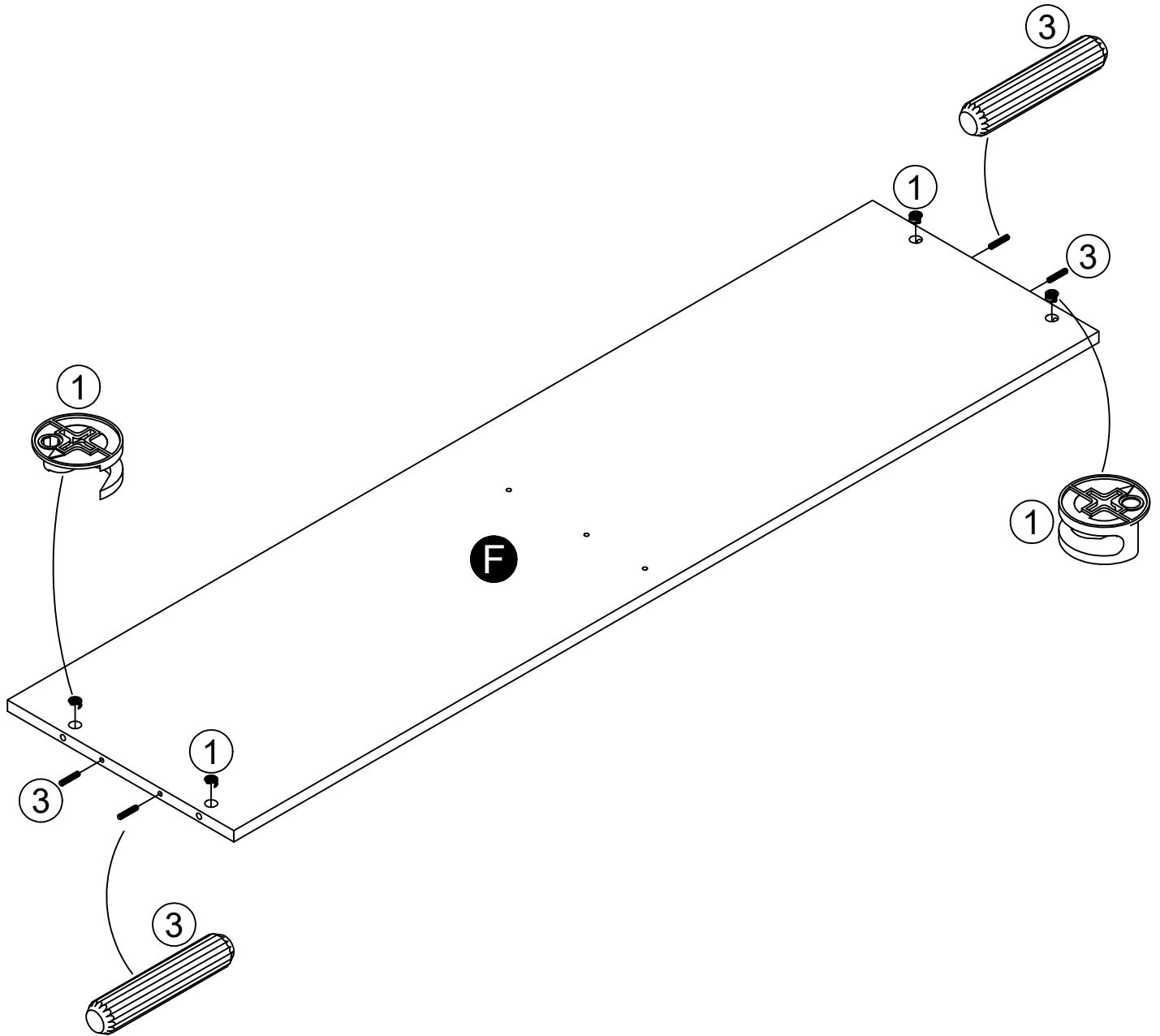

## STEP 9

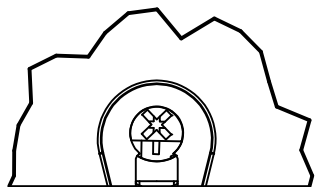
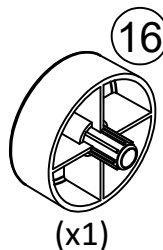
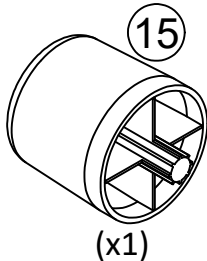
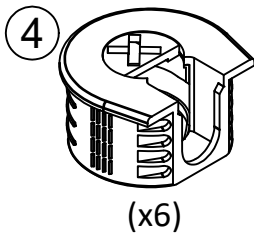
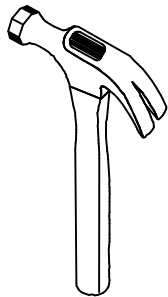

Be sure connector (4) is positioned as shown before inserting into hole. Tap with a hammer to fully insert.

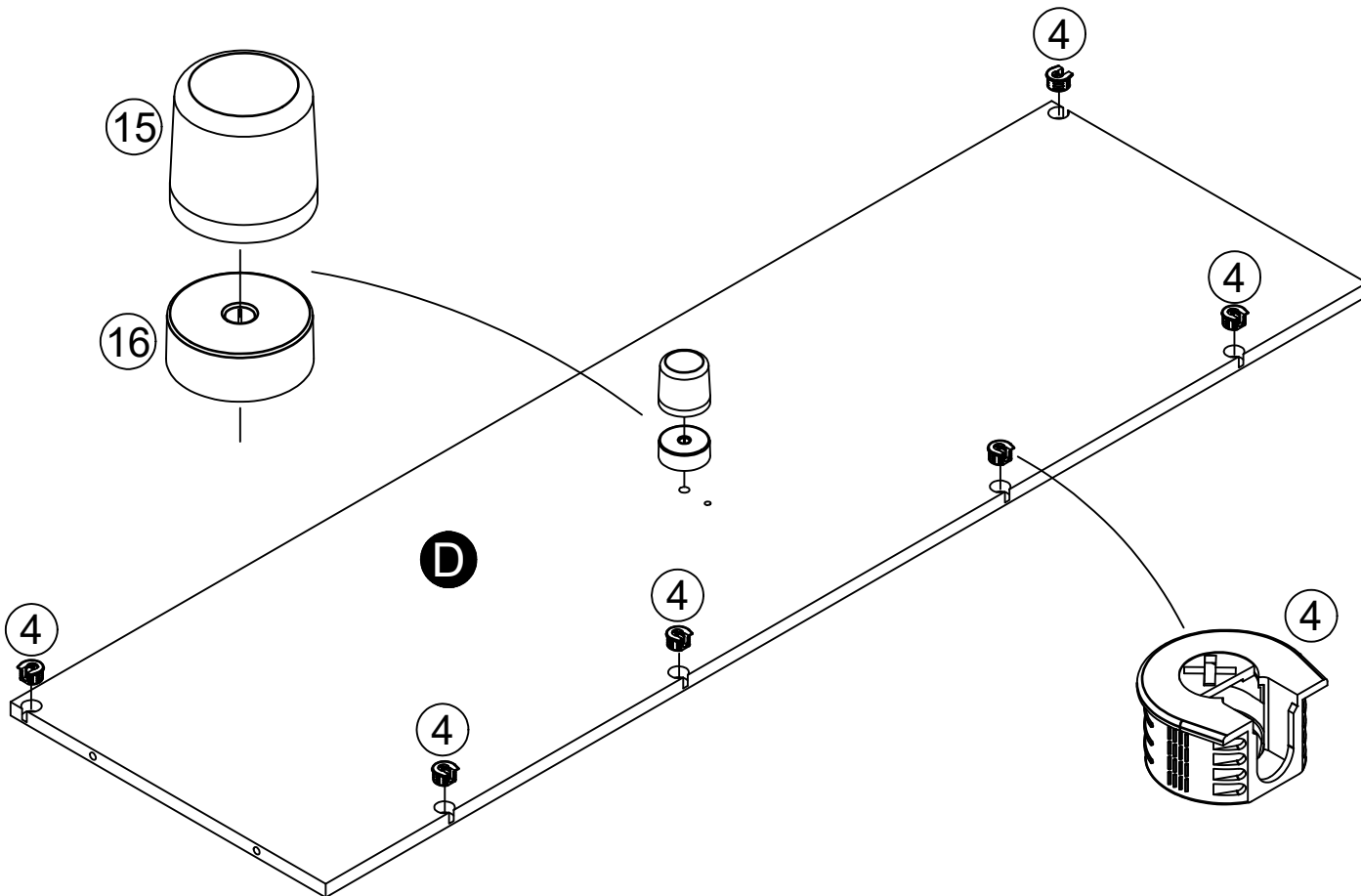

## STEP 10

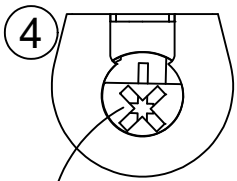
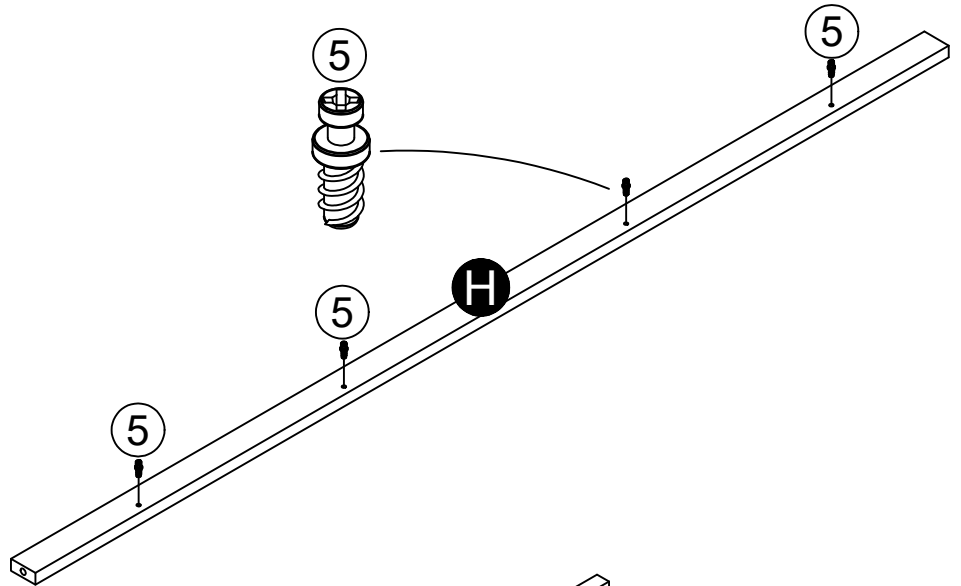
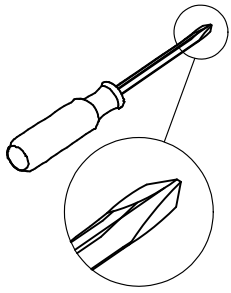

Turn clockwise  
to lock in place.

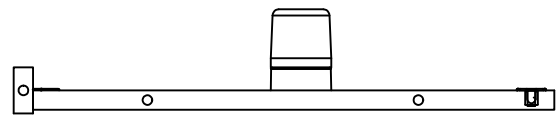
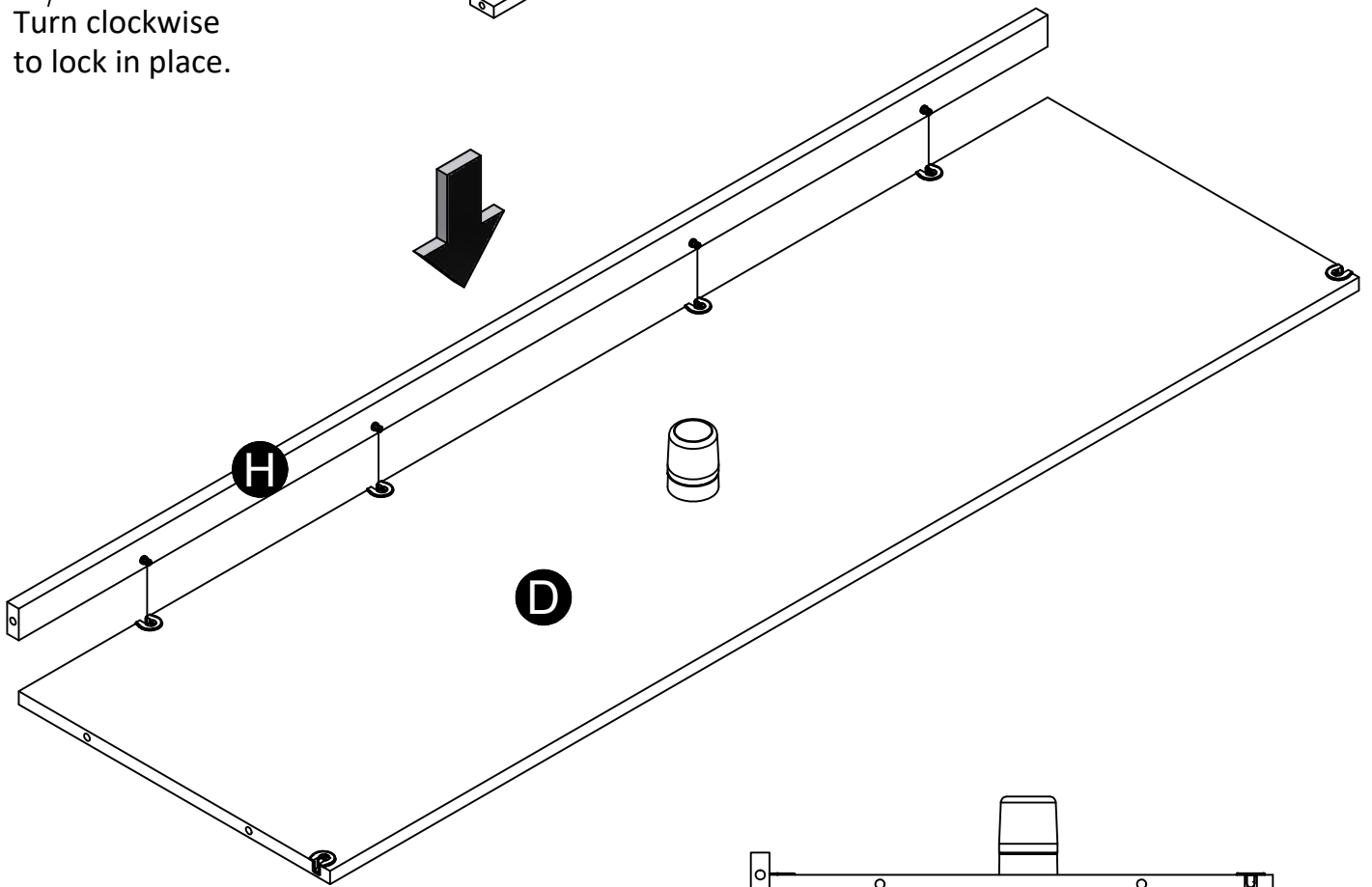
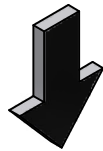

end view



**STEP 12**

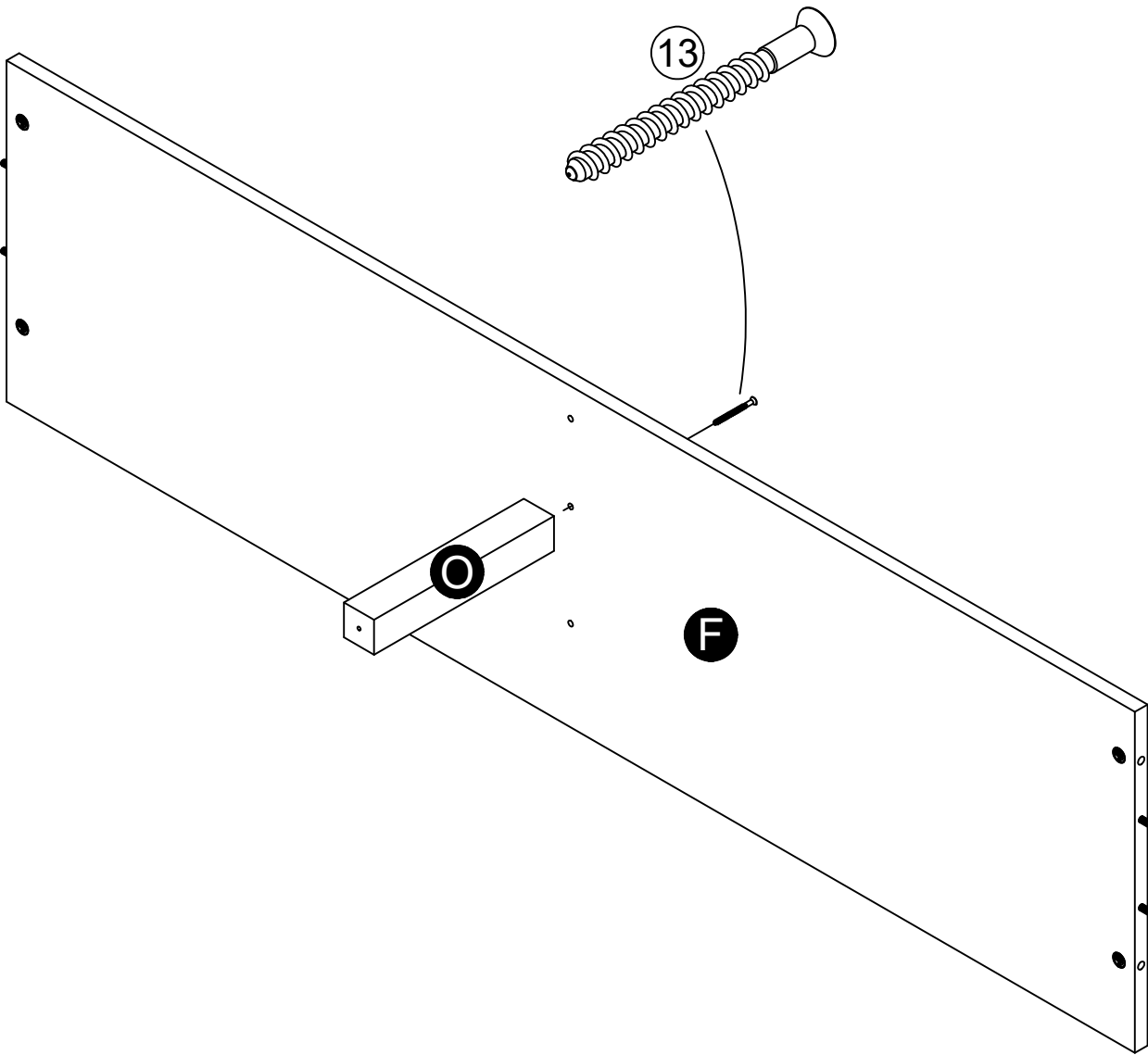
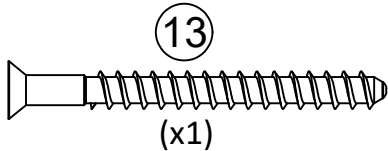
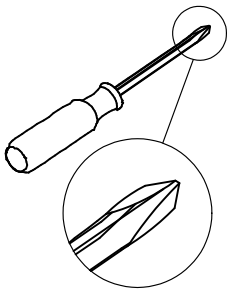

# STEP 13

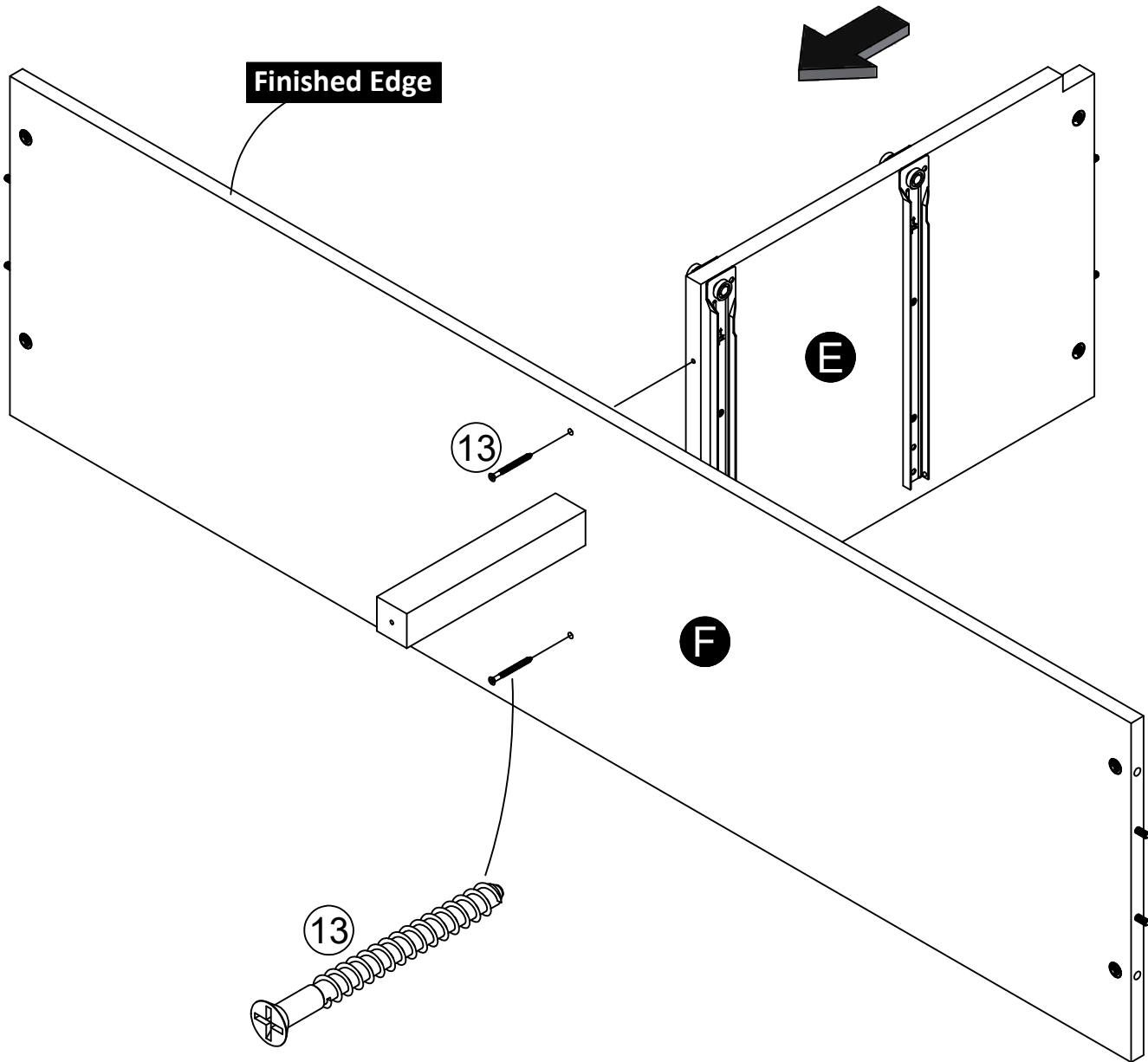
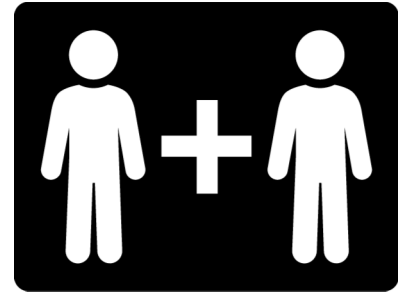
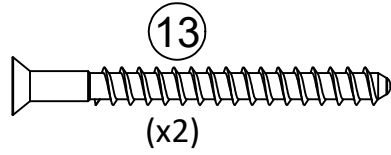
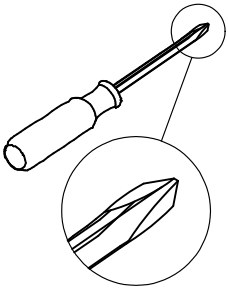

# STEP 14

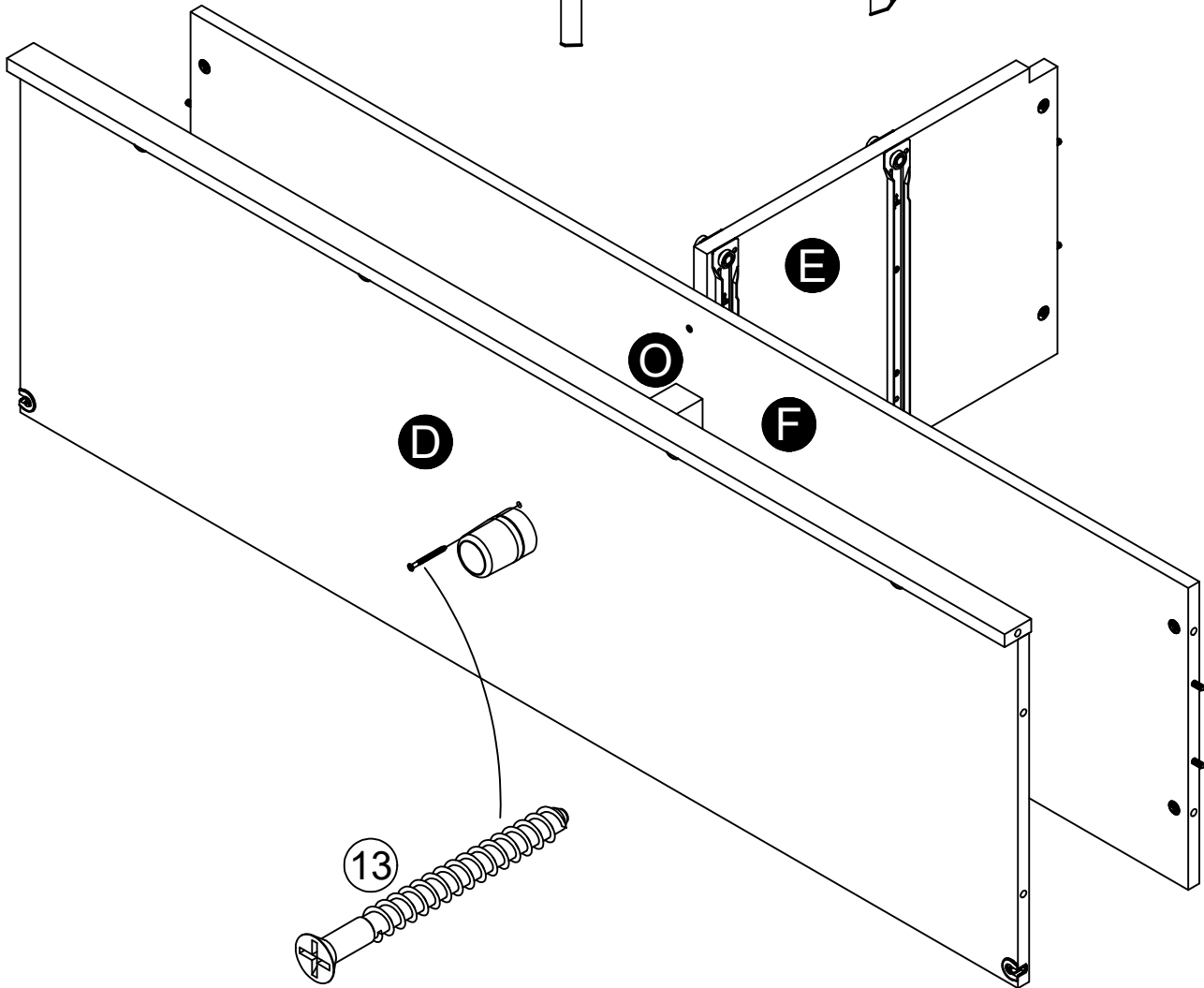
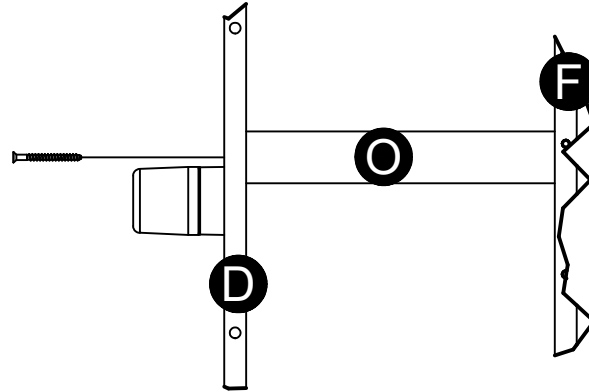
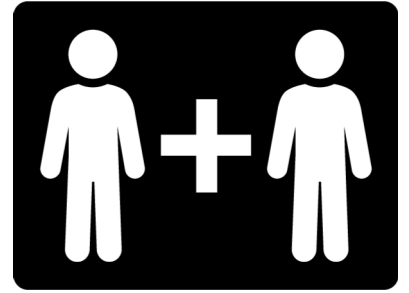
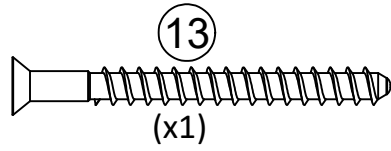
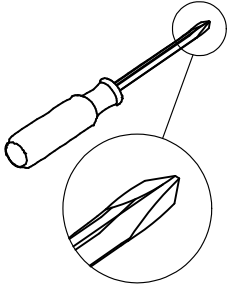

# STEP 15

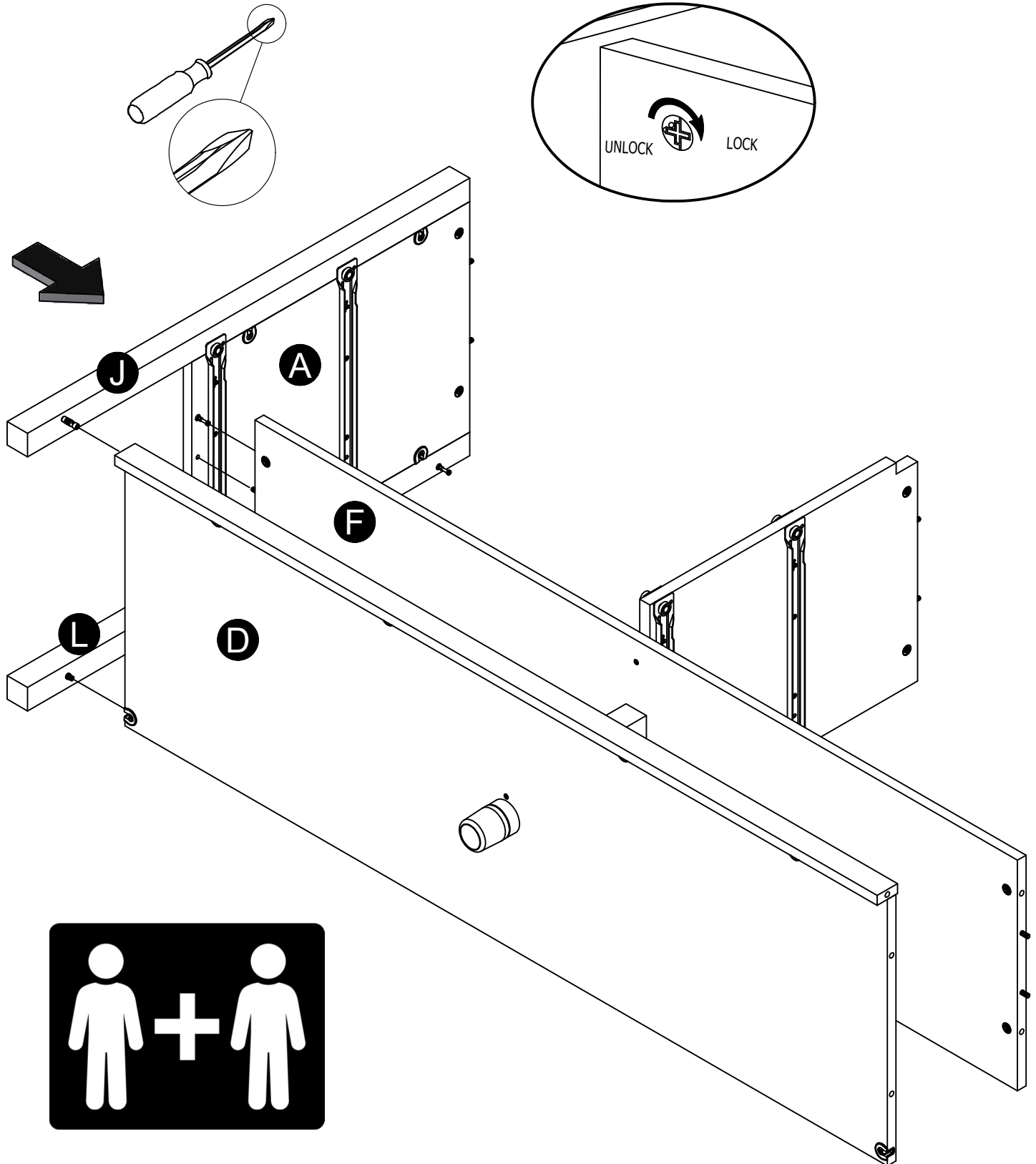



# STEP 16

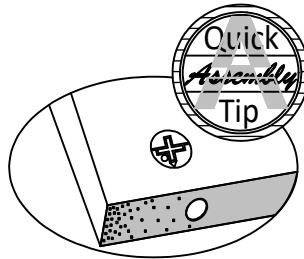

Proper orientation of CAM LOCK

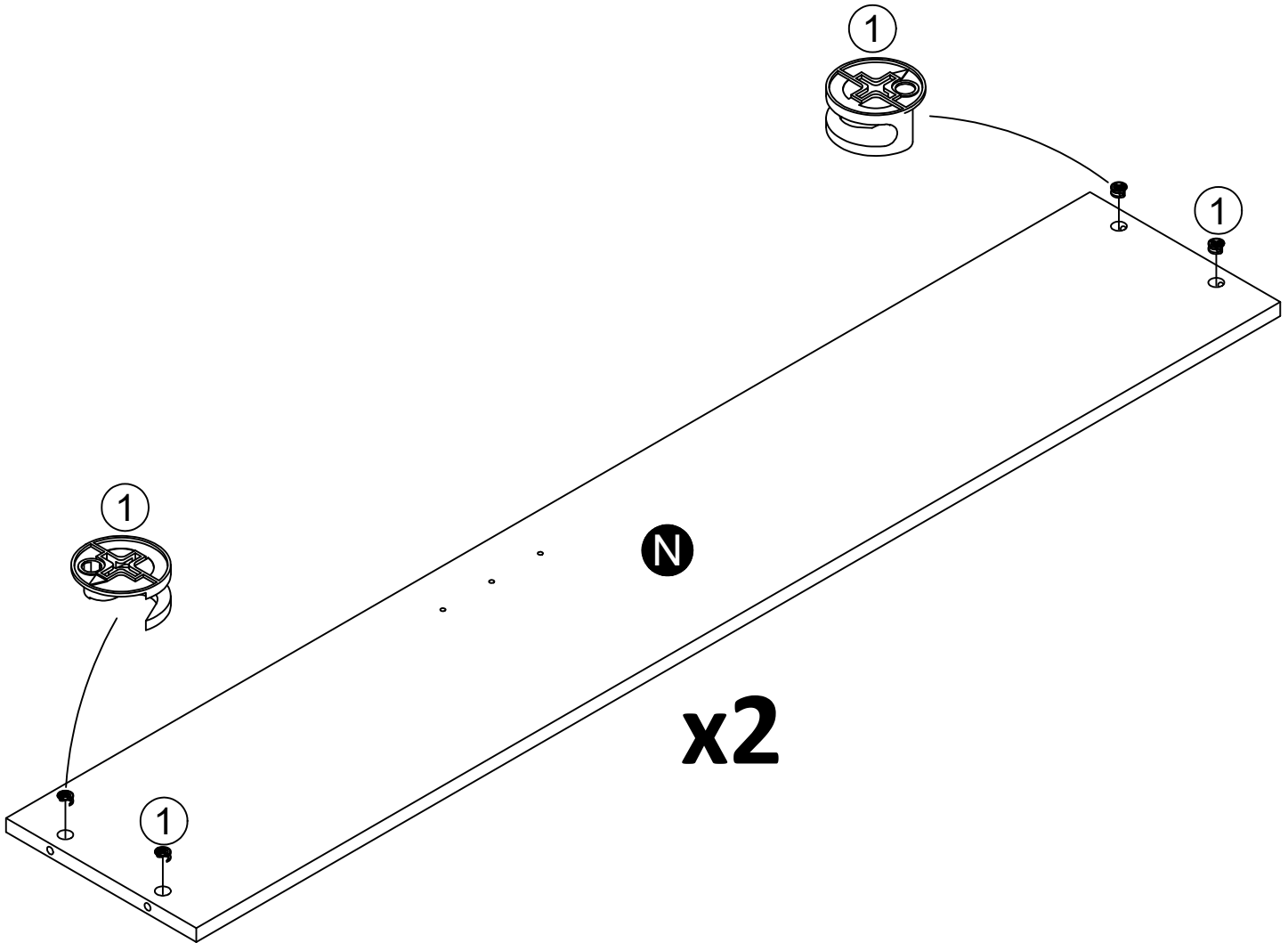

# STEP 17

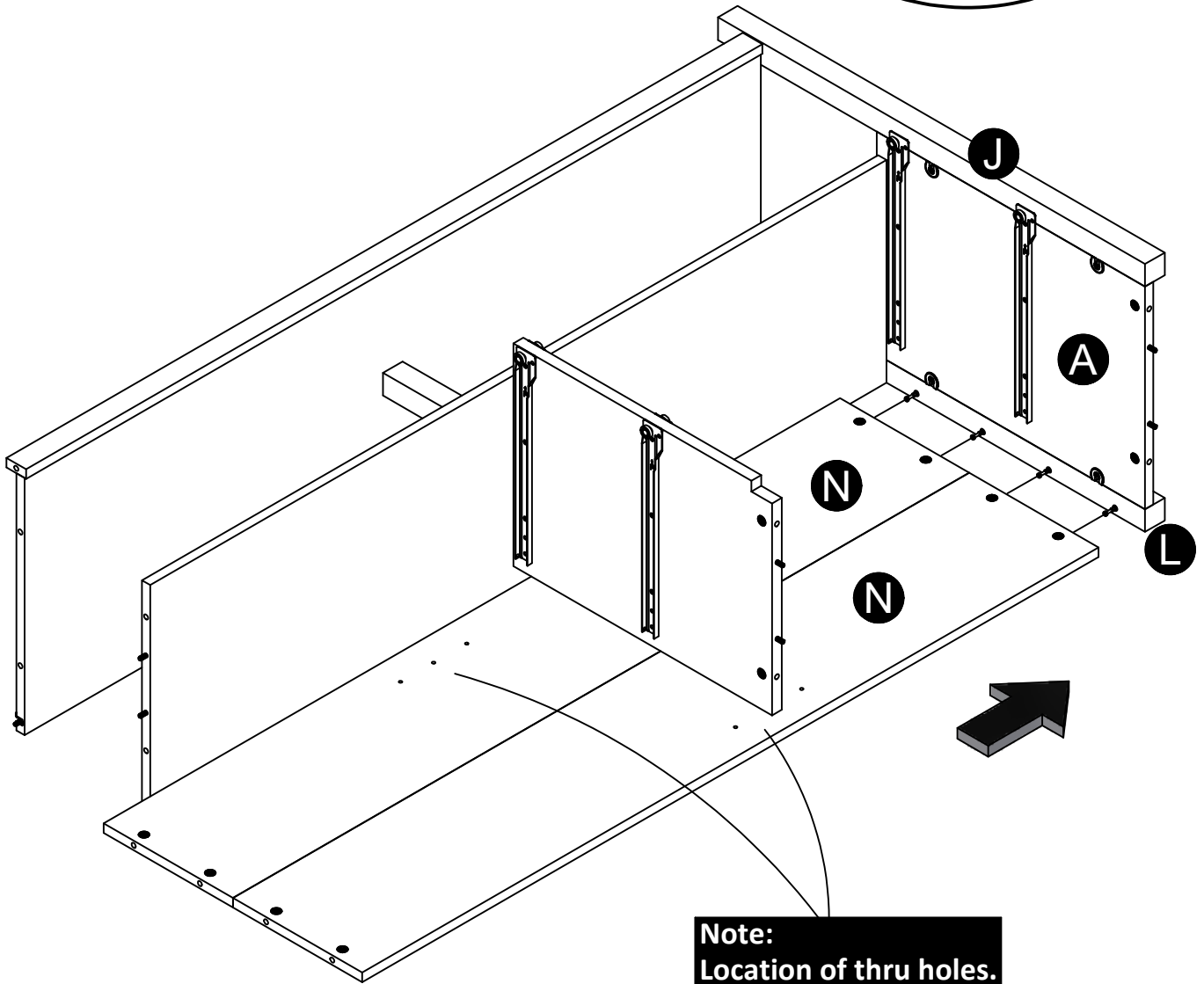
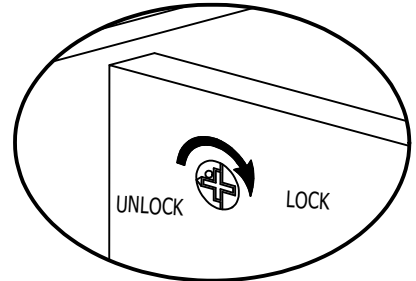
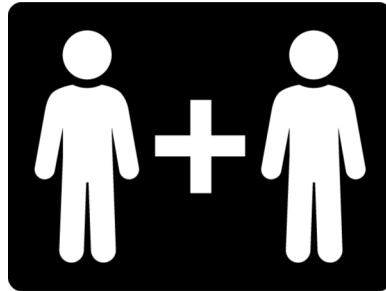
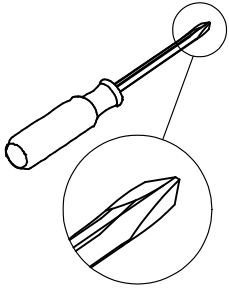

**Note:**  
Location of thru holes.

# STEP 18

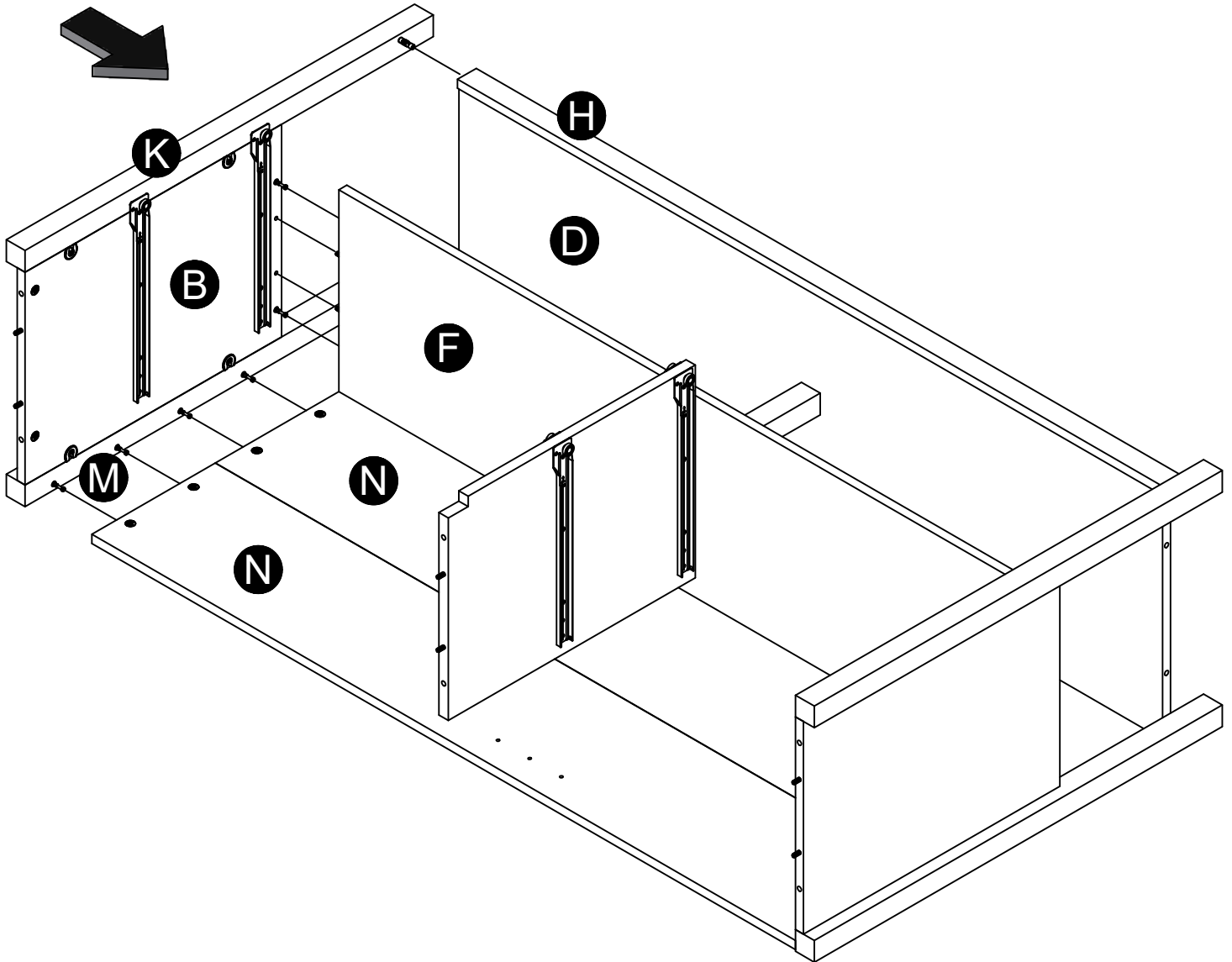
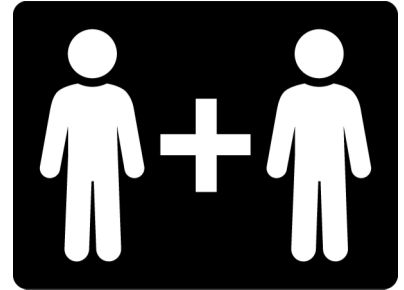
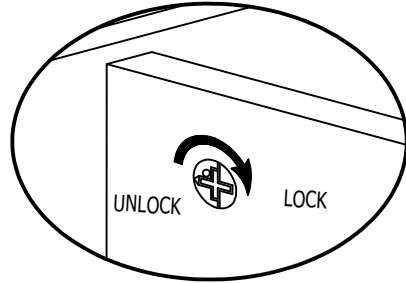
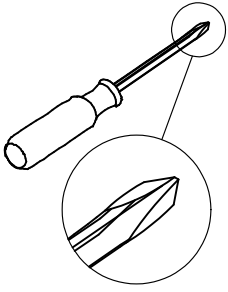

# STEP 19

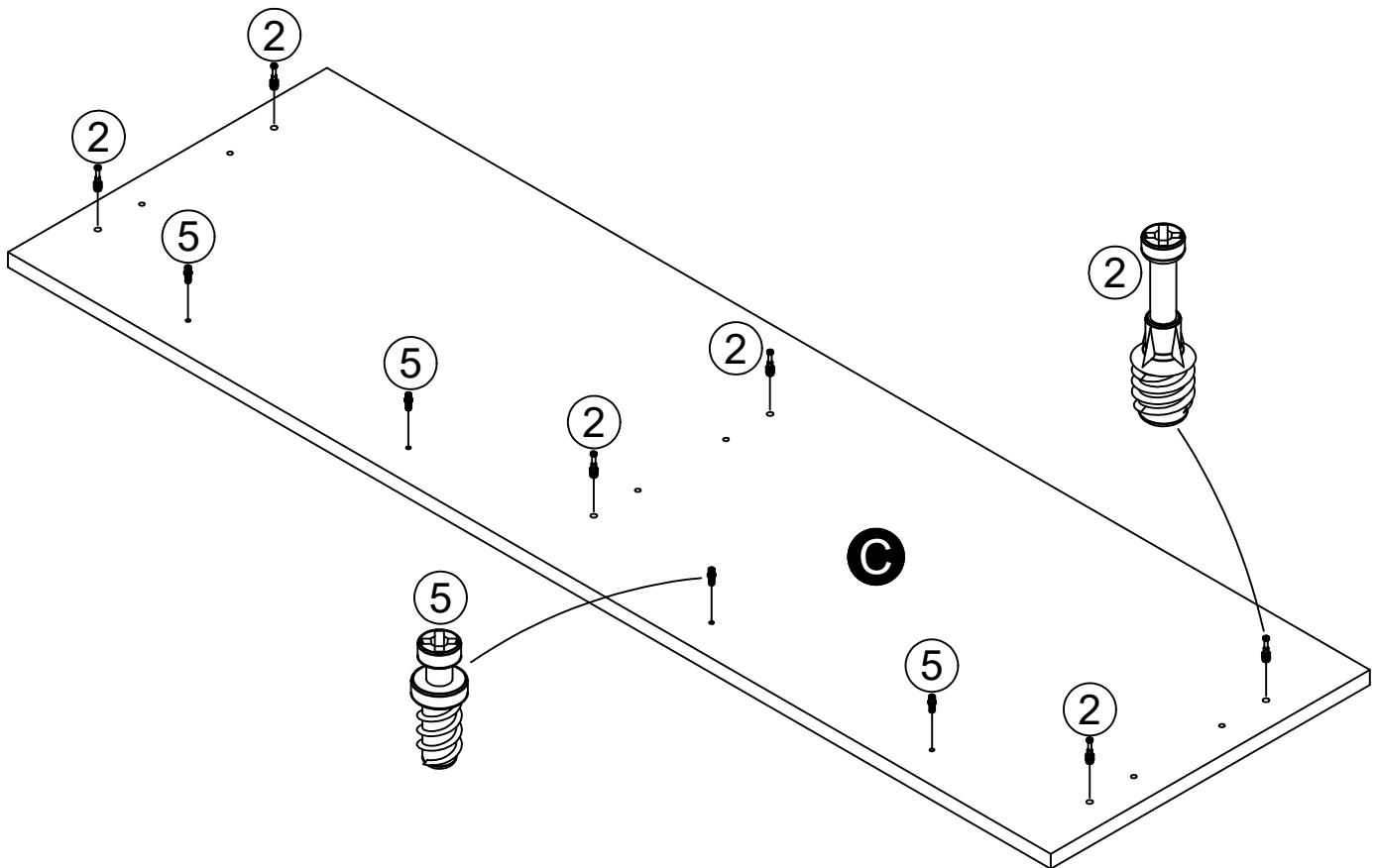
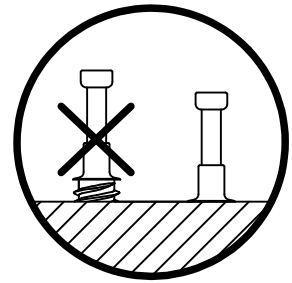
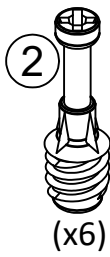
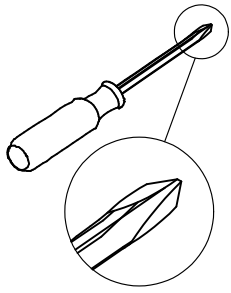

## STEP 20

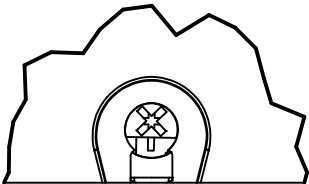
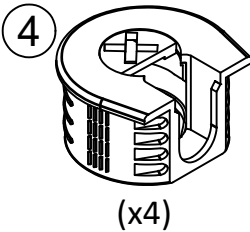
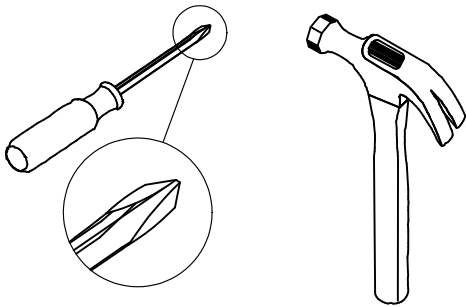

Be sure connector (4) is positioned as shown before inserting into hole. Tap with a hammer to fully insert.

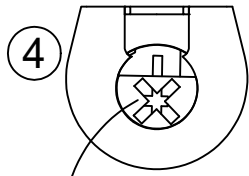
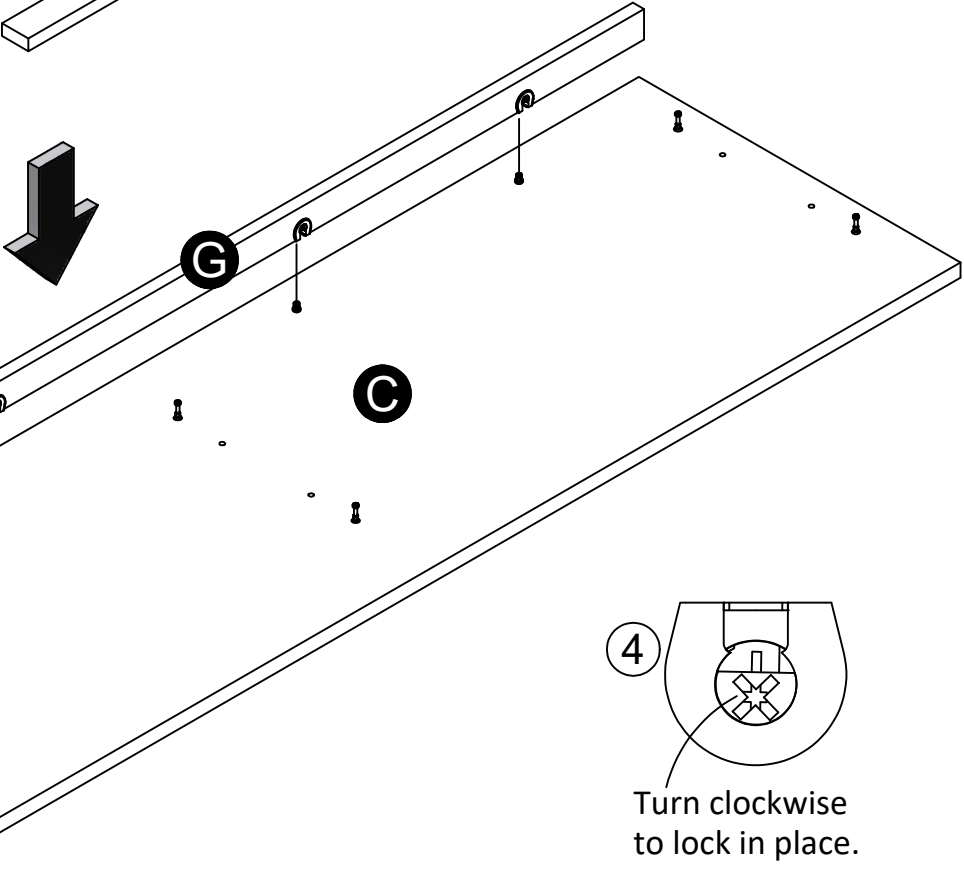
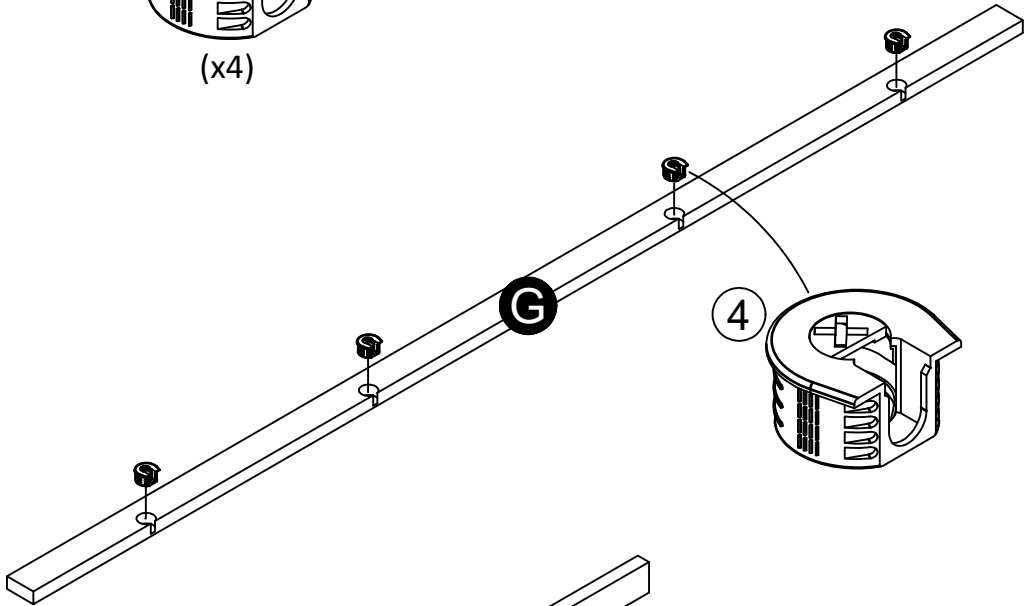

Turn clockwise to lock in place.

# STEP 21

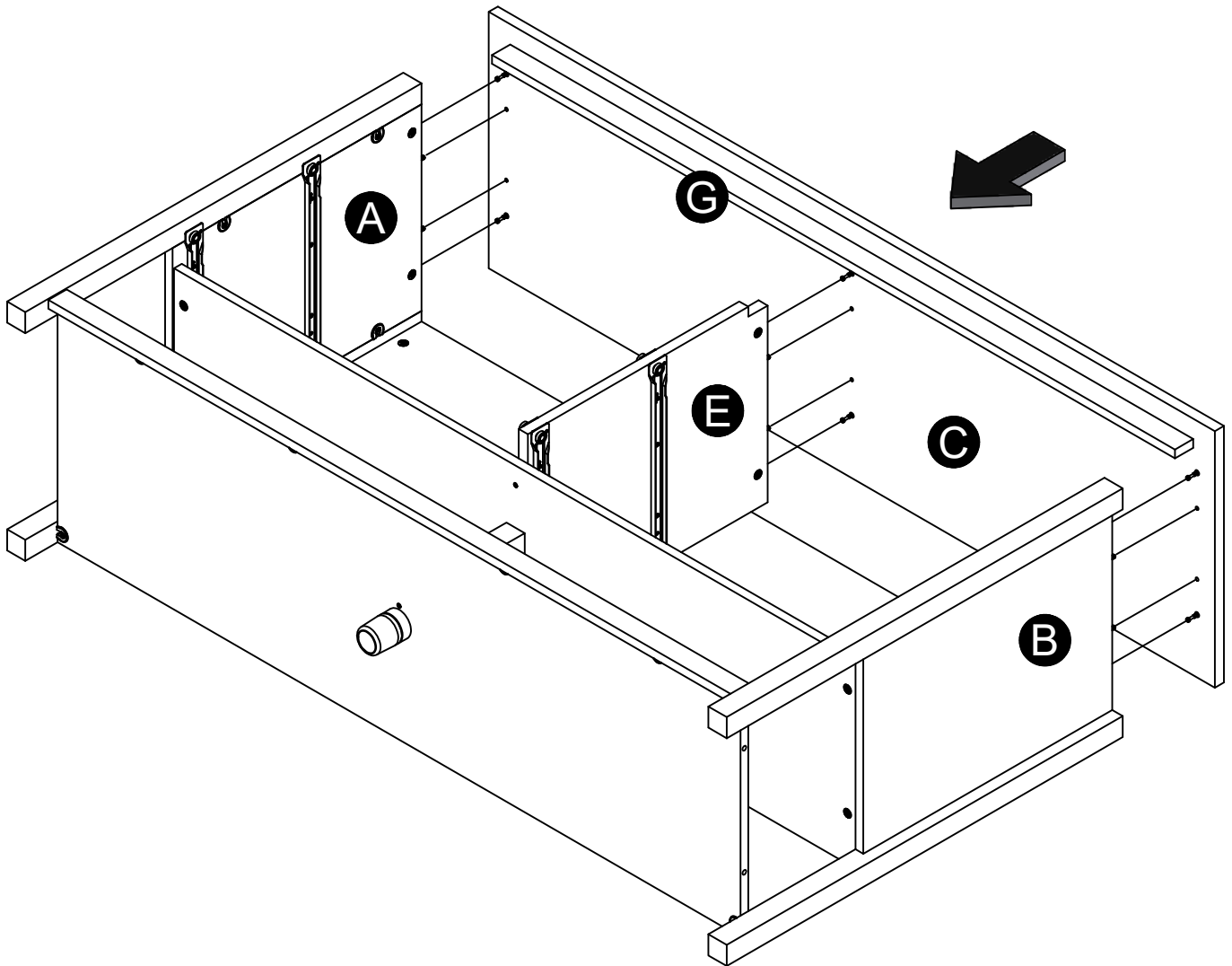
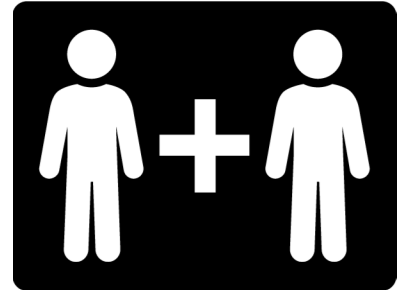
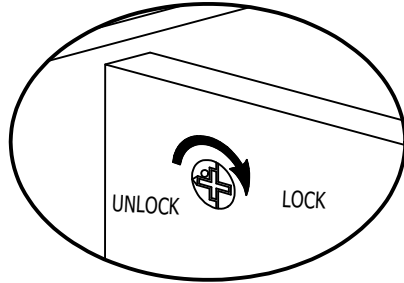
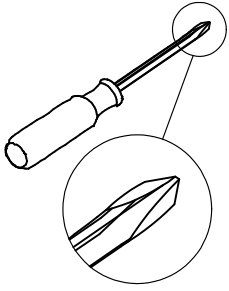

# STEP 22

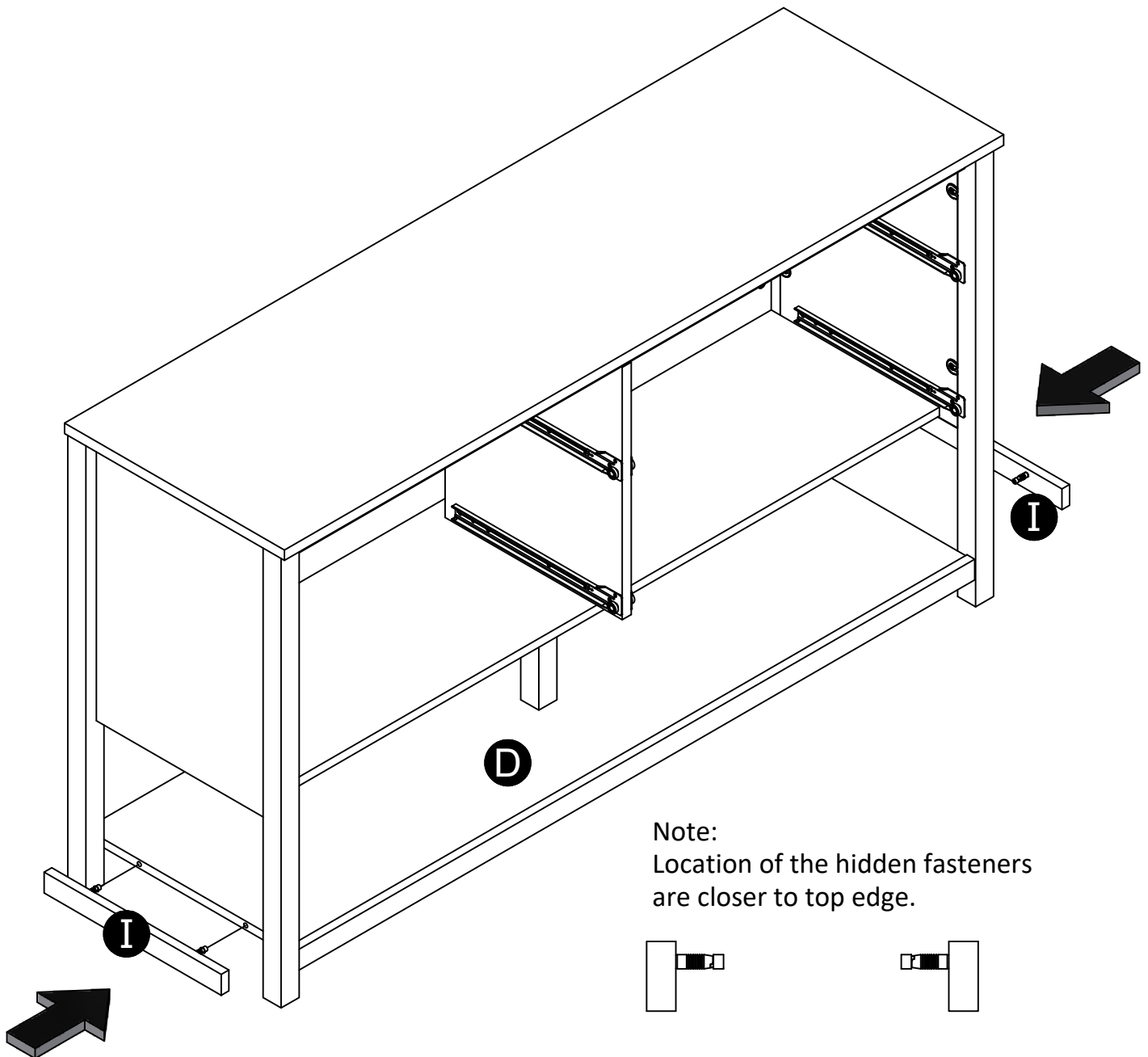
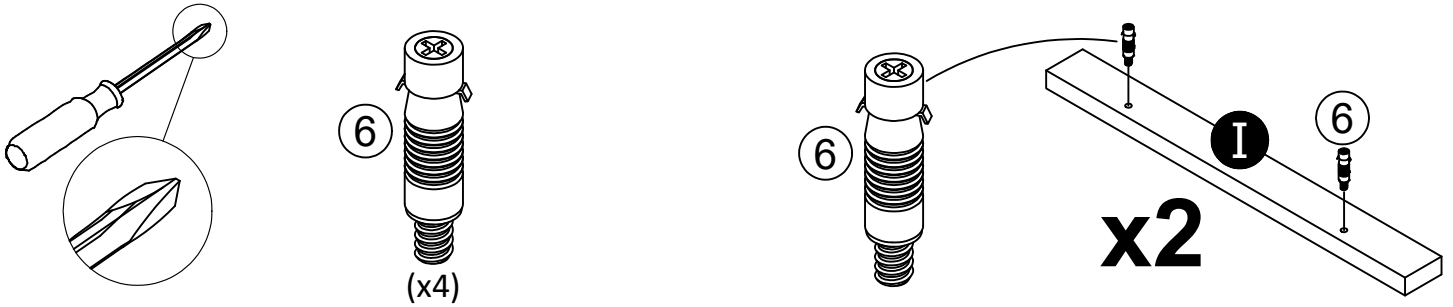

## STEP 23

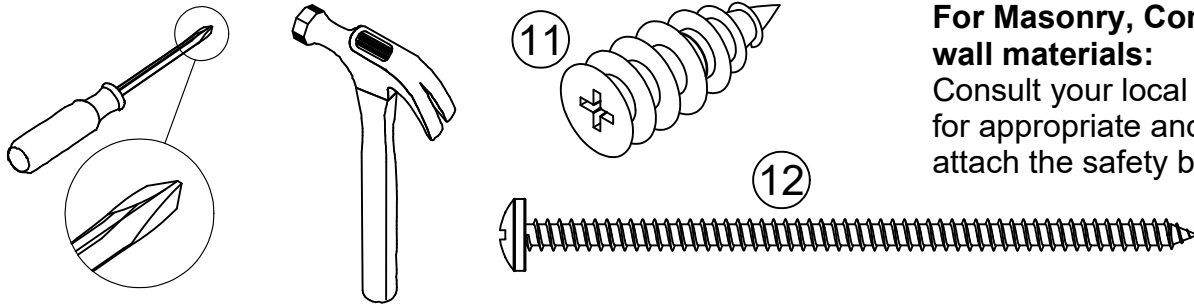

**For Masonry, Concrete, or other wall materials:**  
Consult your local hardware store for appropriate anchors to securely attach the safety bracket.

**IMPORTANT:** THIS UNIT MUST BE SECURE TO THE WALL TO HELP PREVENT TIPOVER. FOLLOW THESE INSTRUCTIONS TO INSTALL THE ANTI-TIPPING SAFETY BRACKET PROVIDED WITH THIS PRODUCT.

### WARNING

**Serious or fatal crushing injuries can occur from furniture tipover.**

#### To prevent tipover:

- \* Install tipover restraint provided
- \* Place heaviest items in the lowest drawers
- \* Unless specifically designed to accommodate, do not set TVs or other heavy objects on the top of this product
- \* Never allow children to climb or hang on drawers, door, or shelves
- \* Never open more than one drawer at a time

**Use of tipover restraints may only reduce, but not eliminate the risk of tipover**

Note:

You have three holes to use to line up with a stud.

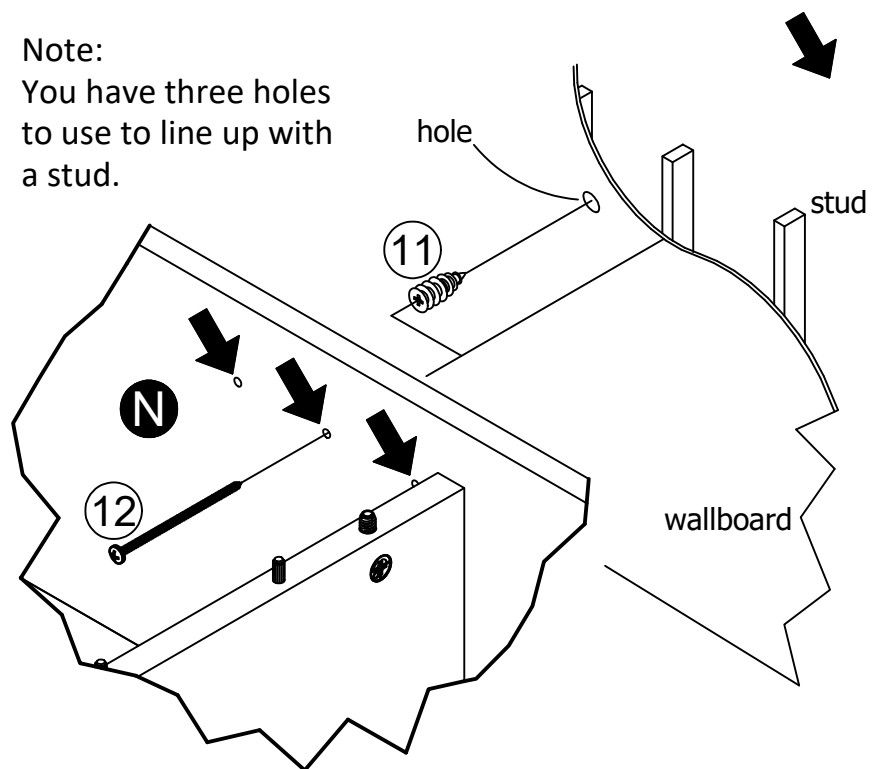

### OPTION 1: Attachment into a wall stud (preferred method)

Using a stud finder, locate a stud in the wall. Place your unit against the wall, with one of the three holes aligned in this location. To make driving the screw easier, you can drill a 1/8" diameter pilot hole (3mm) through the hole in solid back into the stud. Drive the screw through the hole into the wall stud.

### OPTION 2: Attachment into drywall

Locate your unit where desired against a wall and mark the wall through one of the three holes, then move your unit aside. Drill a 3/16" diameter hole (5mm) into the wallboard. Tap the wall anchor into the hole until it is flush. Move your unit back into the same location. Fasten the dresser to the wall anchor with the screw.



# STEP 24

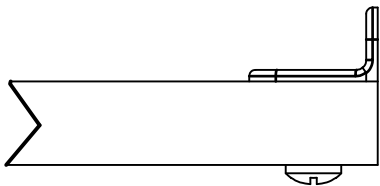
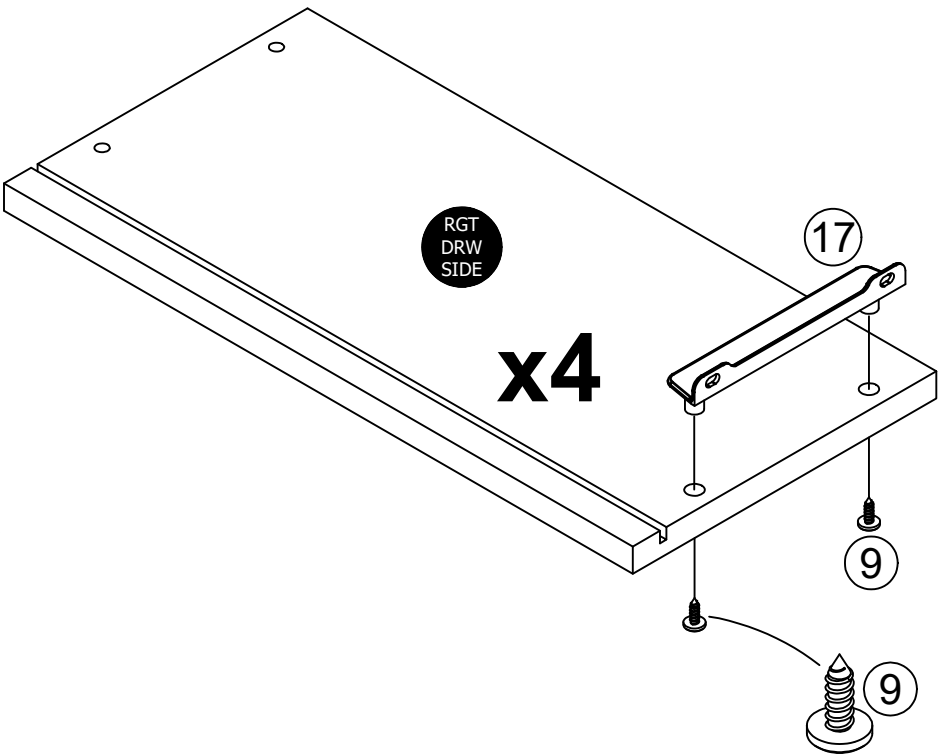
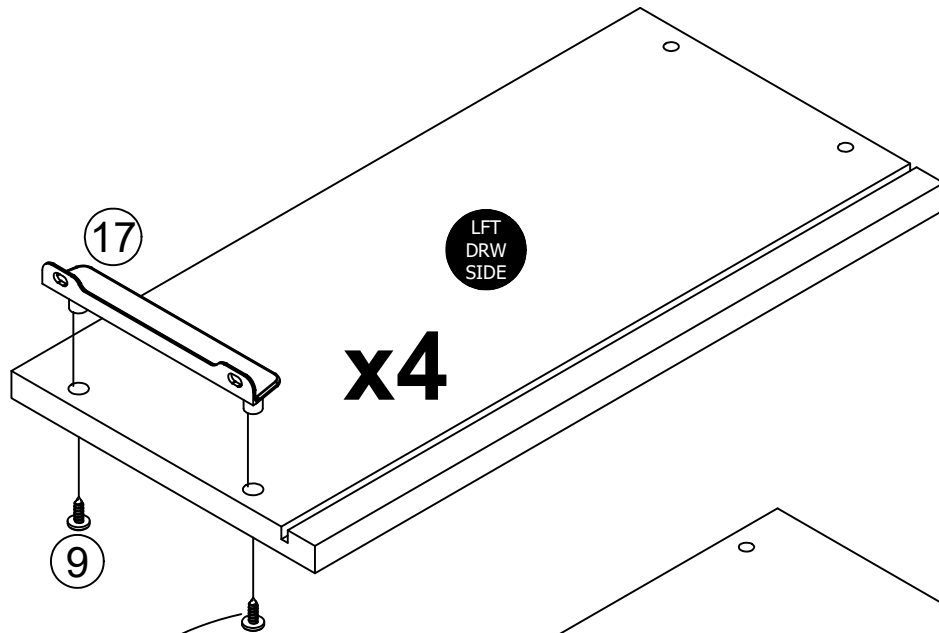
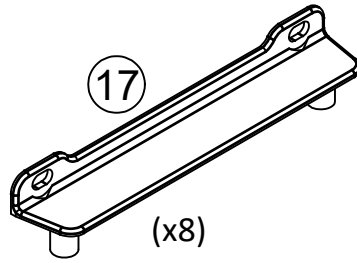
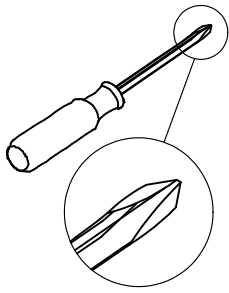

side view

## STEP 25

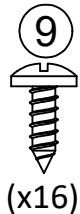
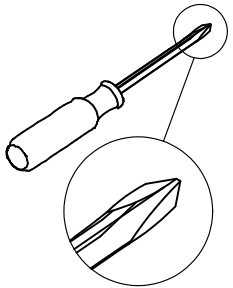

**NOTE:**

You will assemble two (2) Left Side Drawers with Drawer Front "P" and two (2) Right Side Drawers with Drawer Front "Q".

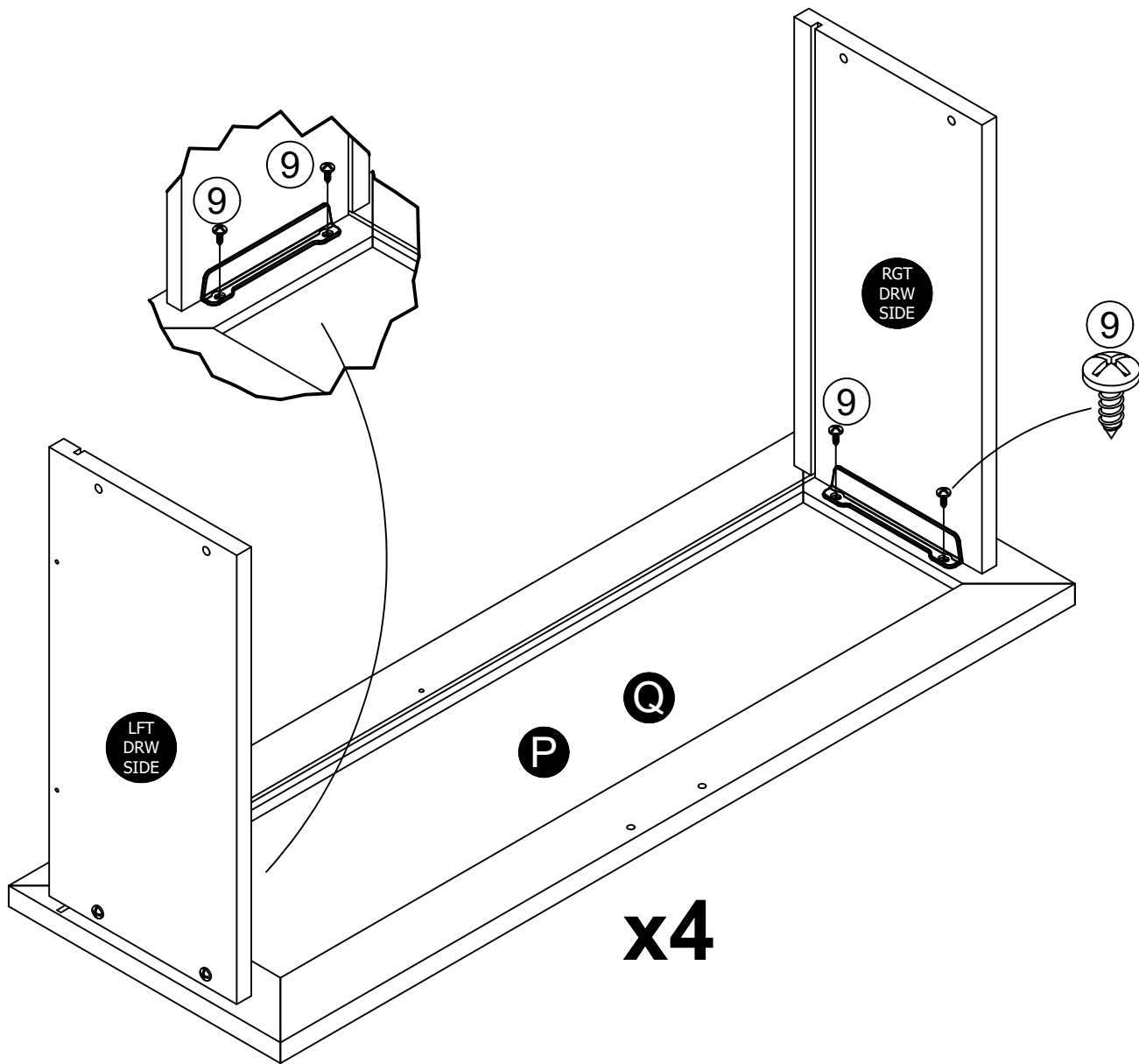

# STEP 26

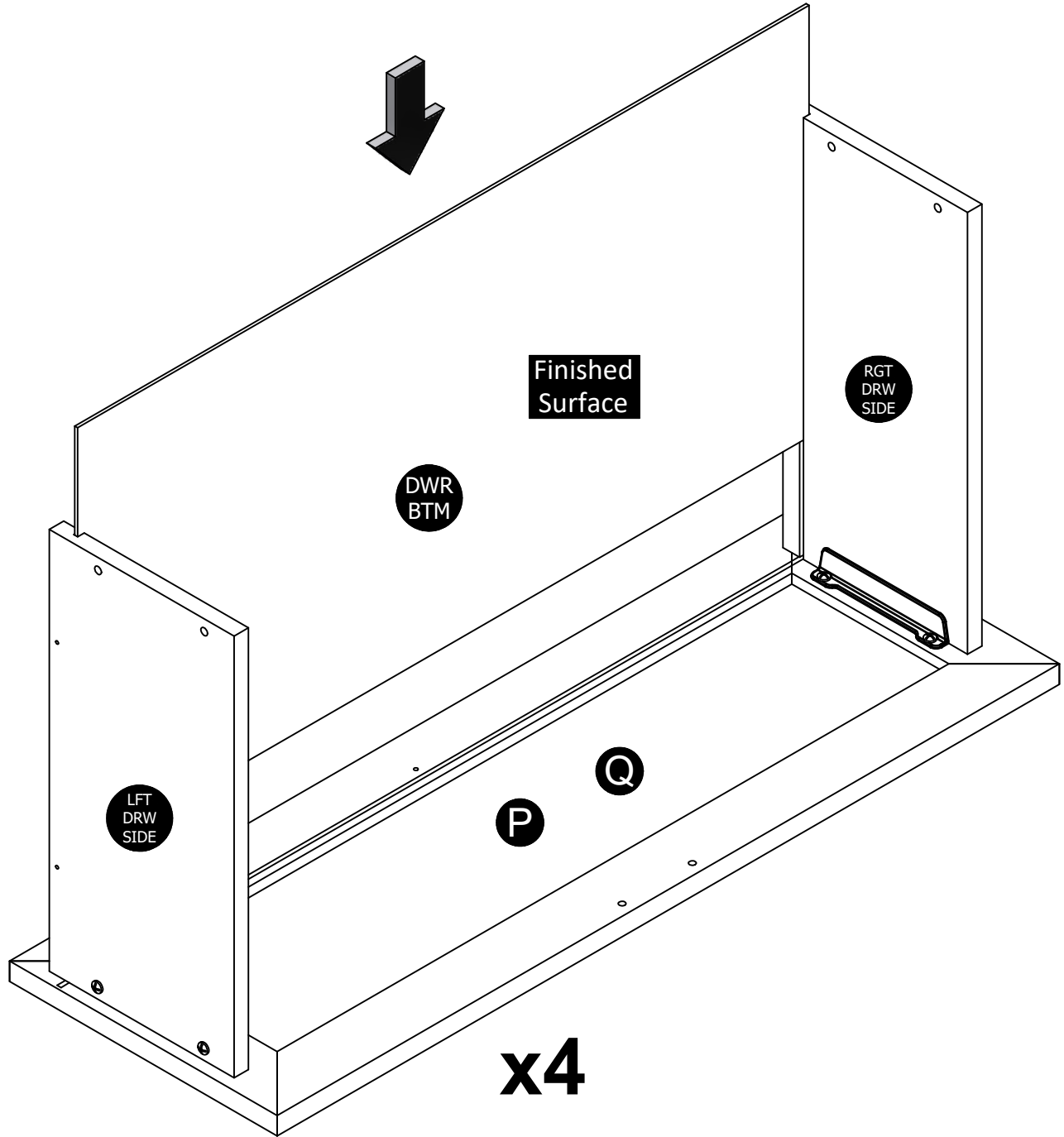



# STEP 28

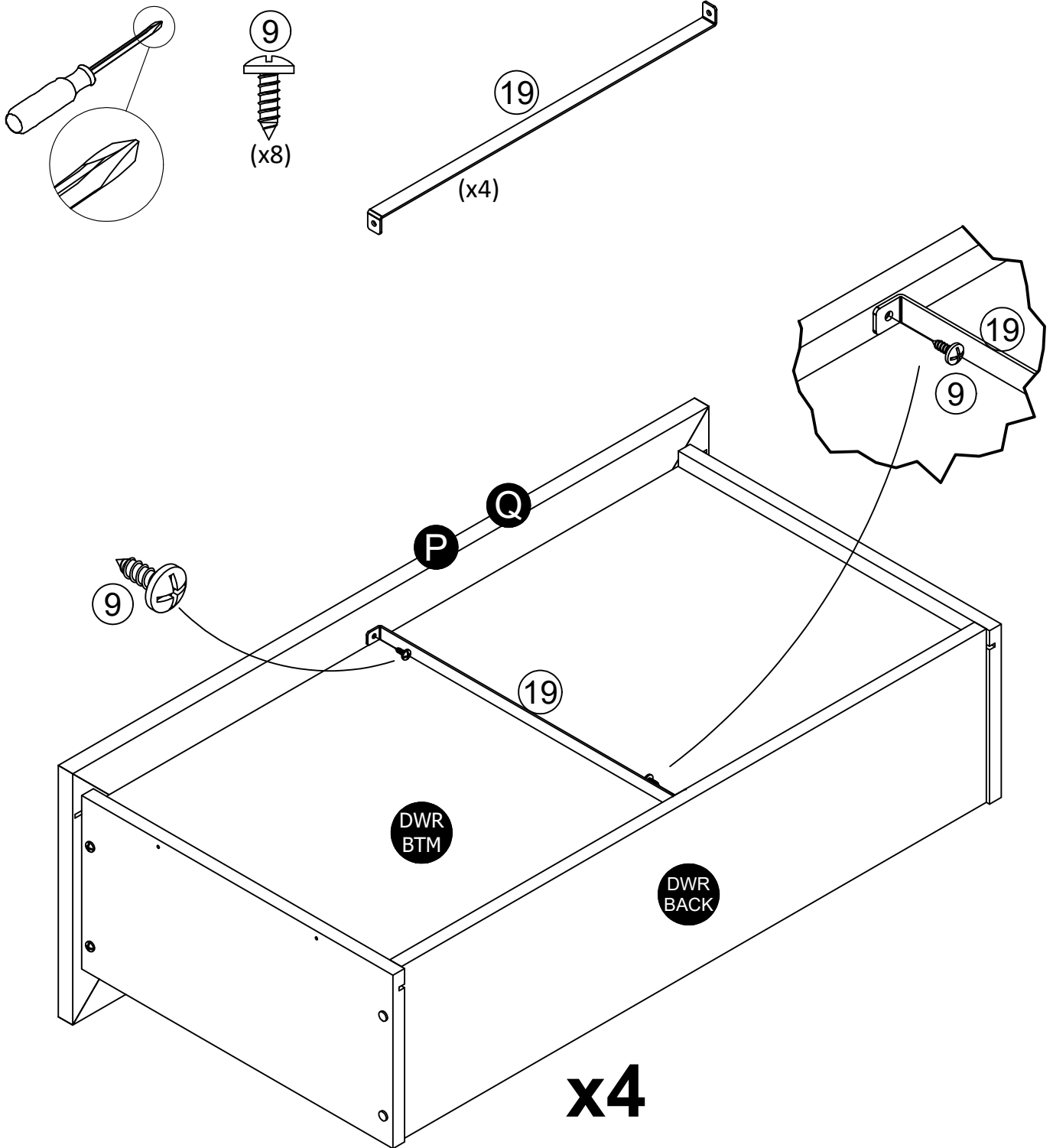

# STEP 29

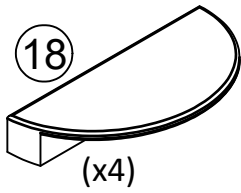
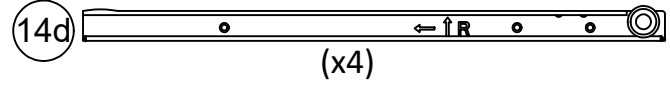
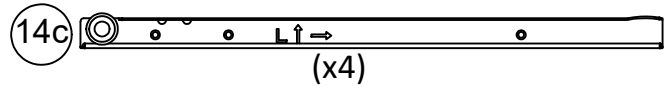
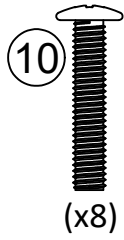
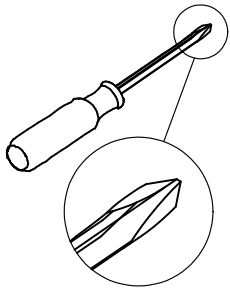

Attach the slides first and the handle.

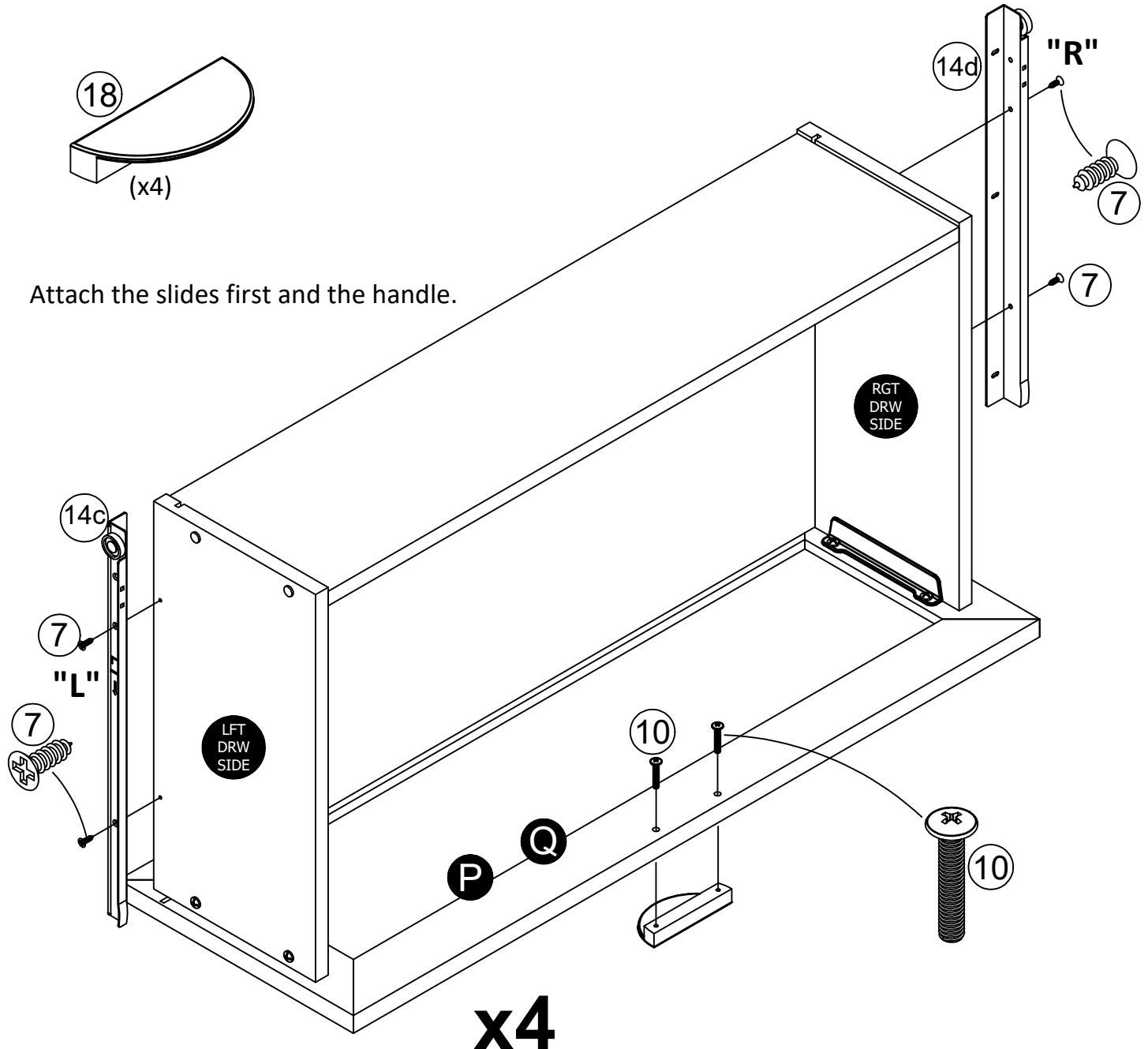

## STEP 30

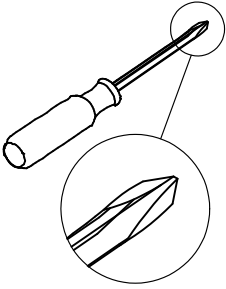

Note: The drawer bracket holes are slotted. Drawer front can be adjusted by loosening screws, making needed adjustments and retightening screws.

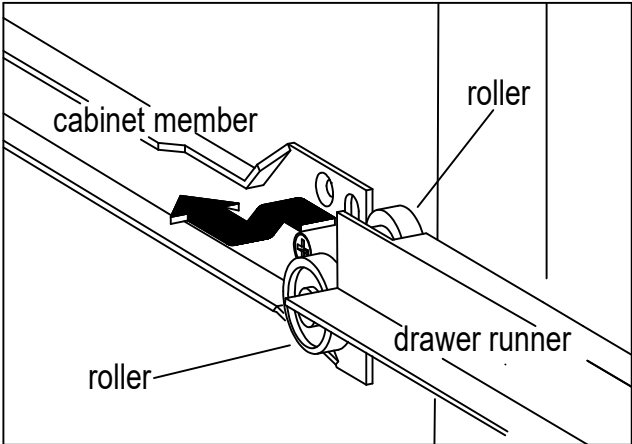
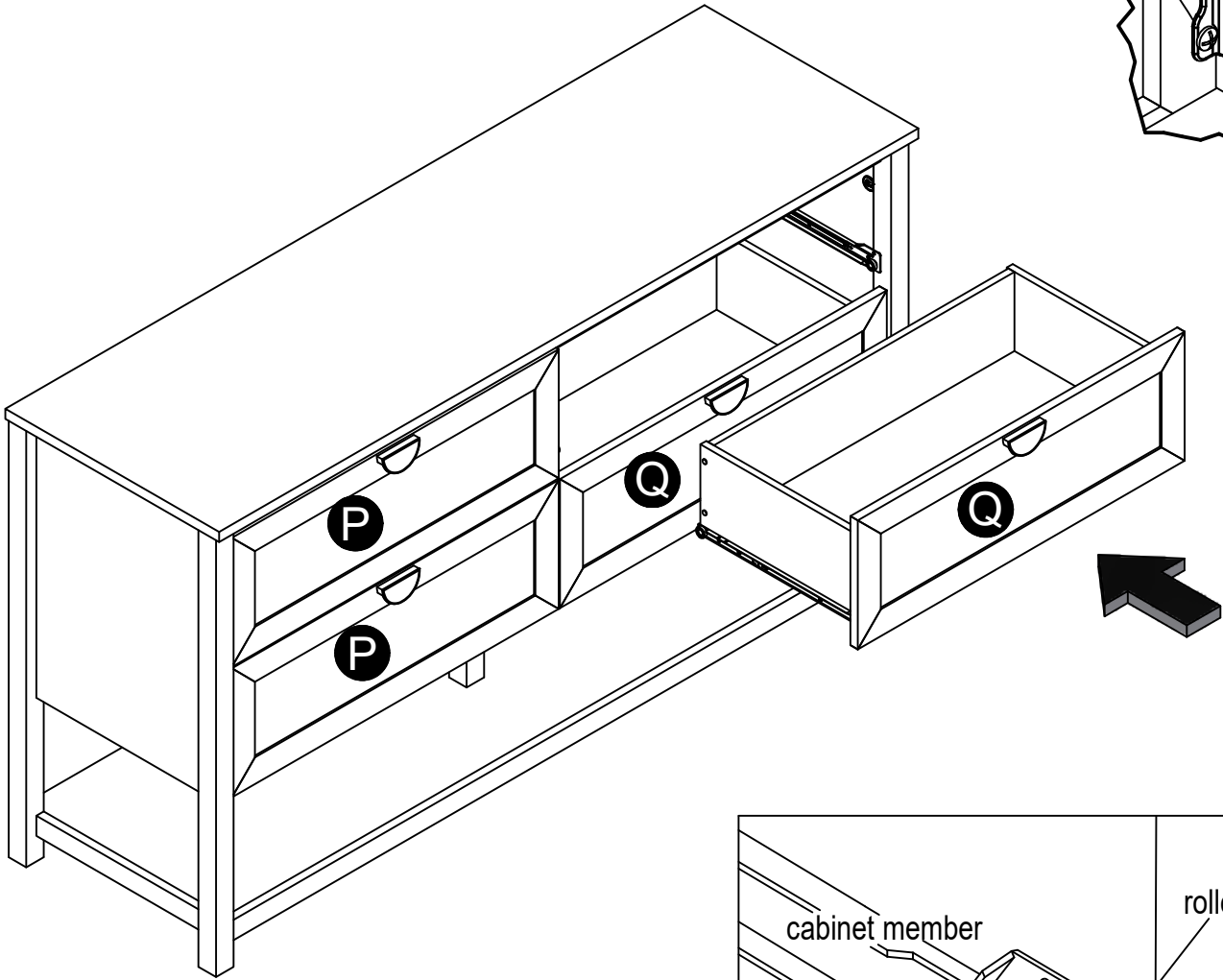
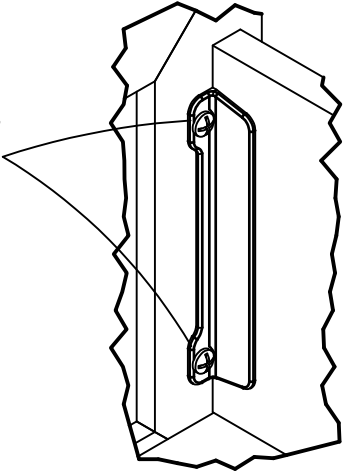

## Maximum Loads

This unit has been designed to support the maximum loads shown. Exceeding these load limits could cause sagging, instability, product collapse, and/or serious injury.

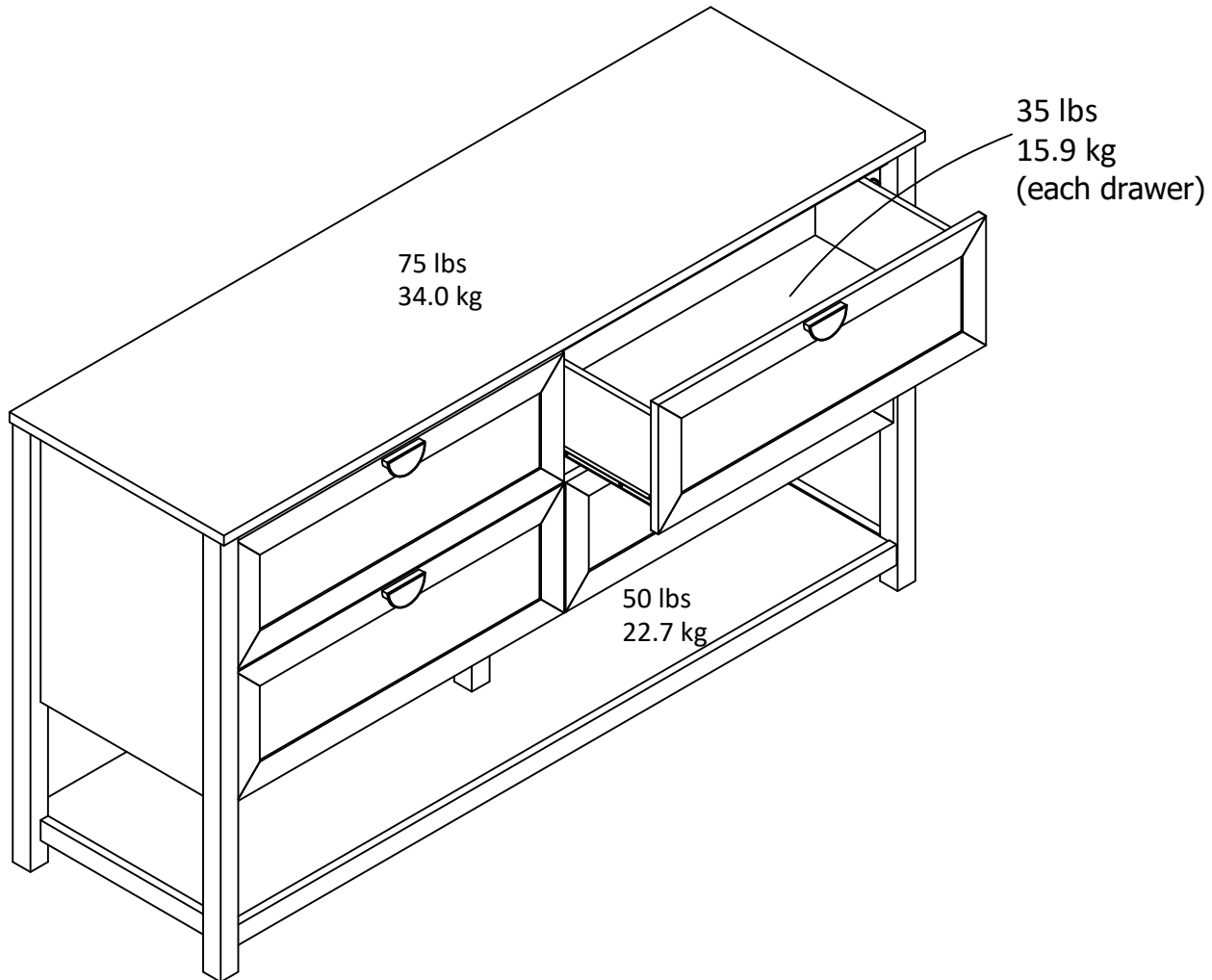

**Warning: Risk of injury to persons - do not place a television on this furniture. This furniture is not approved for use with a television.**

### Certificate of Conformity

1. This certificate applies to the Dorel Home Furnishings, Inc. product identified by this instruction manual.
2. This certificate applies to compliance of this product with the CPSC Ban on Lead-Containing Paint (16 CFR 1303).
3. This product is distributed by: Dorel Home Furnishings, Inc.  
410 East First Street South  
Wright City, MO 63390  
636-745-3351
4. Site of Manufacture: Dowagiac MI
5. See front page of instruction manual for date of manufacture.



## Register your product to receive the following:



- \* New trend details - sneak peek on what's new
- \* Surveys - have a voice within our community
- \* Exclusive deals and discount codes
- \* Quick and easy replacement part service

To register your product, visit [ameriwoodhome.com](http://ameriwoodhome.com)

## *5 Star Rating*



Visit your local retailer's website, rate your purchased product and leave us some feedback!

We would like to extend a big "Thank You" to all of our customers for taking the time to assemble this Ameriwood Home product, and to give us your valuable feedback.

*Thank  
You!*

## Cubierta Delantera

Este libro de instrucciones contiene información **IMPORTANTE** de seguridad. Por favor lea y manténgalo para referencia en el futuro.

**No Regrese este producto!** Comuníquese con nuestro amigoso equipo de servicio al cliente para obtener ayuda.

Llámenos al: 1-800-489-3351 (Gratis) Lunes - Viernes 9am - 5pm CST

Visitar: [www.ameriwoodhome.com](http://www.ameriwoodhome.com)

## PRECAUCION

Este mueble puede volcarse y causar graves heridas y/o muerte.

Anclar el mueble a un poste de madera en la pared (si esto se requiere).

No Permita que los niños monten el mueble.

Mantenga los artículos más pesados en los cajones de abajo.

## Consejos Útiles (página 2)

- Abra su artículo en el área donde usted planea utilizarlo para evitar levantar y moverlo menos
- Identificar, ordenar y contar las piezas antes de intentar ensamblar
- Las clavijas de compresión se golpean con un martillo
- Las diapositivas están marcadas con una R (derecha) y L (izquierda) para la colocación correcta
- Asegúrese de que siempre este el punto localizado en la parte superior de bloqueador de leva este volteado hacia borde exterior
- Utilizar todos los clavos para el panel de atrás y distribuirlos por igual
- El panel de atrás debe utilizarse para asegurarse de que la unidad quede fija y firme
- No use químicas fuertes ni limpiadores abrasivos en este artículo
- Nunca empuje, tire ni arrastre los muebles

## Antes de Que Empieces (página 3)

- Lea cuidadosamente cada paso y siga el orden correcto
- Separar y contar todas sus piezas y hardware
- Dése suficiente espacio para el proceso de ensamble
- Tenga las siguientes herramientas: destornillador de cabeza plana, #2 cabeza Phillips  
Destornillador y martillo
- Precaución: Si usa un taladro electrónico o un destornillador eléctrico para atornillar, por favor asegúrese que deje de atornillar cuando el tornillo este apretado. Fallar hacer esto puede causar barrer el tornillo.

## Sistema de fijar el bloqueo de leva (página 3)

Esta sistema de fijar el bloqueo de leva sera usado en todo el proceso ensamble.

## **Página 10, 11, 18, 29**

Asegúrese de que el conector (4) esté colocado como se muestra antes de insertarlo en el orificio. Martille para insertarlo completamente.

## **Página 13**

Para fijar las patas de la izquierda, tanto delantera (J) como trasera (L), colóquelas como se muestra. Presione hacia abajo para que los pernos de las patas encajen con los conectores (4). Gire el tornillo del conector (4) en el sentido de las agujas del reloj para fijarlo en su sitio.

Gire en el sentido de las agujas del reloj para fijarlo.

## **Página 15**

Para fijar las patas de la derecha, tanto delantera (J) como trasera (L), colóquelas como se muestra. Presione hacia abajo para que los pernos de las patas encajen con los conectores (4). Gire el tornillo del conector (4) en el sentido de las agujas del reloj para fijarlo en su sitio.

## **Página 31**

Nota:

La ubicación de los pasadores ocultos está más próxima al borde superior.

## **Página 32**

**Para mampostería, concreto u otros materiales de pared:**

Consulte en su ferretería local los anclajes apropiados para fijar firmemente el soporte de seguridad.

**IMPORTANTE:** ESTA UNIDAD DEBE ASEGURARSE A LA PARED PARA PREVENIR VOLCAMIENTOS. SIGA ESTAS INSTRUCCIONES PARA INSTALAR EL SOPORTE DE SEGURIDAD ANTIVOLCAMIENTO SUMINISTRADO CON ESTE PRODUCTO.

Nota:

Dispone de tres orificios para alinearlos con un entramado.

### **ADVERTENCIA**

**Si este mueble se voltea puede provocar lesiones graves o fatales.**

**Para prevenir volcamientos:**

- \* Instale el dispositivo de sujeción suministrado
- \* Coloque los objetos más pesados en las gavetas más bajas
- \* A menos que esté específicamente diseñado para tal fin, no coloque televisores ni otros objetos pesados encima de este producto
- \* Nunca permita que los niños se suban al mismo, ni que cuelguen de sus gavetas, puertas o repisas
- \* Nunca abra más de una gaveta a la vez

**El uso de dispositivos de sujeción podría solo reducir, mas no eliminar, el riesgo de volcamiento**

## **OPCIÓN 1: Fijación al entramado (método preferido)**

Mediante un buscador de entramado, localice una viga montante en la pared. Coloque su unidad contra la pared, con uno de los tres orificios alineados en esta ubicación. Para facilitar el atornillado, podría taladrar un agujero piloto de 1/8" (3 mm) a través del orificio en la parte posterior sólida y hacia el entramado. Introduzca el tornillo a través de dicho agujero en el entramado de la pared.

## **OPCIÓN 2: Fijación a paneles de yeso**

Ubique su unidad contra una pared de su elección y marque dicha pared a través de uno de los tres orificios; a continuación, haga a un lado su unidad. Taladre un agujero de 3/16" (5 mm) a través del panel de yeso de la pared. Martille suavemente el anclaje de pared dentro del agujero hasta que quede al ras. Ponga la unidad de vuelta en el mismo lugar. Con la ayuda del tornillo, fije el aparador al anclaje de pared.

## **Página 34**

NOTA:

Ensamblará dos (2) gavetas laterales izquierdas con frontal de gavetas "P" y dos (2) gavetas laterales derechas con frontal de gavetas "Q".

## **Página 38**

Fije los rieles primero y luego la manilla.

## **Página 39**

Nota: Los agujeros del soporte de la gaveta son ranurados. Los frontales de las gavetas pueden ajustarse aflojando los tornillos, realizando los ajustes necesarios y volviendo a apretar los tornillos.

## **Página 40**

CARGA MAXIMA

Esta unidad ha sido diseñada para soportar las cargas máximas indicadas. Exceder estos límites de carga podría causar hundimiento, inestabilidad, colapso del producto y/o lesiones graves.

**Advertencia: existe riesgo de lesiones a las personas, no ponga un televisor sobre este mueble. Este mueble no está aprobado para su uso con un televisor.**

## **Página 41**

Registre su producto para recibir lo siguiente:

- \* Detalles de nuevas tendencias - Vistazo a lo nuevo
- \* Encuestas - alec su voz entre su comunidad
- \* Códigos de ofertas y descuentos exclusivos
- \* Fácil y rápido servicio de partes de remplace

Para registrar su producto, visite [ameriwoodhome.com](http://ameriwoodhome.com)

Clasificación de 5 estrellas

Visite el sitio web de su tienda local, califique su comprado y denos sus comentarios!

Nos gustaría enviar un gran "Agradecimiento" a todos nuestros clientes por tomarse el tiempo de ensamblar este producto de Ameriwood Home, y por darnos sus valiosos comentarios.

Gracias

## Couverture Avant

CE LIVRET D'INSTRUCTION CONTIENT DES INFORMATIONS **IMPORTANTES** SUR LA SÉCURITÉ. VEUILLEZ LIRE ET GARDER POUR UNE RÉFÉRENCE FUTURE

**Ne retournez pas ce produit!** Contactez notre équipe de service à la clientèle amicale d'abord pour obtenir de l'aide.

**Appelez-nous:** 1-800-489-3351 (sans frais) du Lundi au Vendredi de 9h à 17h Heure Centrale

**Visitez:** [www.ameriwoodhome.com](http://www.ameriwoodhome.com)

## ATTENTION

Le meuble peut basculer et causer des blessures graves ou la mort.

Ancrer le meuble à une planche murale dans le mur (si indiqué).

Ne laissez pas les enfants grimper sur le meuble.

Placez les articles lourds sur les étagères ou dans les tiroirs inférieurs.

## Astuces Utiles (page 2)

-Ouvrez votre article dans la zone que vous prévoyez de le garder pour moins de levage lourd

-Identifier, trier et compter les pièces avant d'essayer d'assembler

-Les goujons de compression sont taraudés avec un Marteau

-Les glissières sont marquées d'un R (droit) et d'un L (gauche) pour un bon placement

-Assurez-vous toujours de faire face la pointe situé sur le haut de la Serrure de Came vers le bord extérieur

-Utiliser tous les clous fournis pour le panneau arrière et les répartir également

-Le panneau arrière doit être utilisé pour vous assurer que votre appareil est robuste

-N'utilisez pas de produits chimiques agressifs ou de nettoyeurs abrasifs sur cet appareil

-Ne jamais pousser, tirer, ou faire glisser votre meuble

## Avant de Commencer (page 3)

-Lisez attentivement chaque étape et suivez le bon ordre

-Séparez et comptez toutes vos pièces et matériaux

-Donnez-vous suffisamment de place pour l'assemblage

-Avoir les outils suivants: tournevis à tête plate, #2 tournevis Phillips, et Marteau

-Attention: Si vous utilisez une perceuse électrique ou un tournevis électrique pour visser, veillez à ralentir et arrêter lorsque la vis est bien serrée. Le non-respect de cette consigne peut endommager la vis.

## Système de Fixation de Came (page 3)

Ce Système de Fixation de Came sera utilisé tout au long de l'assemblage

## Page 10, 11, 18, 29

Assurez-vous que le connecteur (4) est positionné comme indiqué avant de l'insérer dans le trou. Tapez avec un marteau pour l'insérer complètement.

## Page 13

Pour fixer le pied avant gauche (J) et le pied arrière gauche (L), positionnez-les comme indiqué. Appuyez pour que les boulons d'assemblage des pieds se fixent aux connecteurs (4). Tournez la vis du connecteur (4) dans le sens des aiguilles d'une montre pour le bloquer en place.

Tournez dans le sens des aiguilles d'une montre pour bloquer en place.

## Page 15

Pour fixer le pied avant droit (K) et le pied arrière droit (M), positionnez-les comme indiqué. Appuyez pour que les boulons d'assemblage des pieds se fixent aux connecteurs (4). Tournez la vis du connecteur (4) dans le sens des aiguilles d'une montre pour le bloquer en place.

## Page 31

Note :

L'emplacement des fixations cachées est plus proche du bord supérieur.

## Page 32

**Pour la maçonnerie, le béton ou d'autres matériaux muraux :**

Consultez votre quincaillerie locale pour obtenir des ancrages appropriés afin de fixer solidement le support de sécurité.

**IMPORTANT :** CET APPAREIL DOIT ÊTRE FIXÉ AU MUR POUR ÉVITER TOUT BASCULEMENT. SUIVEZ CES INSTRUCTIONS POUR INSTALLER LE SUPPORT DE SÉCURITÉ ANTI-BASCULEMENT FOURNI AVEC CE PRODUIT.

Note :

Vous avez trois trous à utiliser pour aligner avec un goujon.

### AVERTISSEMENT

**Le basculement d'un meuble peut entraîner des blessures graves ou mortelles par écrasement.**

**Pour éviter le basculement :**

- \* Installez le dispositif de retenue anti-basculement fourni
- \* Placez les articles les plus lourds dans les tiroirs les plus bas
- \* Ne posez pas de téléviseurs ou d'autres objets lourds sur le dessus de ce produit, à moins qu'ils ne soient spécifiquement conçus pour cela
- \* Ne permettez jamais aux enfants de grimper ou de s'accrocher aux tiroirs, aux portes ou aux étagères
- \* Never open more than one drawer at a time

**L'utilisation de dispositifs de retenue en cas de basculement ne peut que réduire, mais pas éliminer, le risque de basculement**

## **OPTION 1 : Fixation dans un montant de mur (méthode préférée)**

À l'aide d'un détecteur de montants, localisez un montant dans le mur. Placez votre appareil contre le mur, avec l'un des trois trous alignés à cet endroit. Pour faciliter l'insertion de la vis, vous pouvez percer un trou pilote de 3 mm de diamètre à travers le trou de l'arrière solide dans le montant. Enfoncez la vis à travers le trou dans le montant du mur.

## **OPTION 2 : Fixation dans les cloisons sèches**

Placez votre unité à l'endroit désiré contre un mur et marquez le mur par l'un des trois trous, puis mettez votre unité de côté. Percez un trou de 3/16 de pouce de diamètre (5 mm) dans le panneau mural. Tapez sur l'ancrage mural dans le trou jusqu'à ce qu'il soit affleurant. Remplacez votre meuble au même endroit. Fixez la commode à l'ancrage mural à l'aide de la vis.

### **Page 34**

#### **NOTE :**

Vous assemblerez deux (2) tiroirs latéraux gauches avec façade de tiroir « P » et deux (2) tiroirs latéraux droits avec façade de tiroir « Q ».

### **Page 38**

Fixez d'abord les glissières et la poignée.

### **Page 39**

Remarque : les trous des supports de tiroir sont fendus. L'avant du tiroir peut être ajusté en desserrant les vis, en effectuant les ajustements nécessaires et en resserrant les vis.

### **Page 40**

#### **CHARGES MAXIMALES**

Cet appareil a été conçu pour supporter les charges maximales indiquées. Le dépassement de ces limites de charge peut entraîner un affaissement, une instabilité, un effondrement du produit et/ou des blessures graves.

**Avertissement : Risque de blessure pour les personnes - ne pas placer un téléviseur sur ce meuble. Ce meuble n'est pas homologué pour être utilisé avec un téléviseur.**



## Page 41

Enregistrez votre produit pour recevoir les éléments suivantes:

- \* Détails sur les nouvelles tendances - un aperçu sur les nouveautés
- \* Sondages - avoir une voix au sein de notre communauté
- \* Offres exclusives et codes promo
- \* Service de pièces de rechange rapide et facile

Pour enregistrer votre produit, visitez [ameriwoodhome.com](http://ameriwoodhome.com)

5 Étoiles

Visitez le site Web de votre détaillant local, évaluez votre produit acheté et laissez-nous quelques commentaires !

Nous tenons à offrir un grand "Merci" à tous nos clients pour avoir pris le temps d'assembler ce produit "Ameriwood Home", et de nous donner vos commentaires précieux.

Merci