

1614341COM 2 Door Storage Unit

Ameriwood HOME

Date of Purchase ___ / ___ / ___
Lot Number:

B341614341COM0

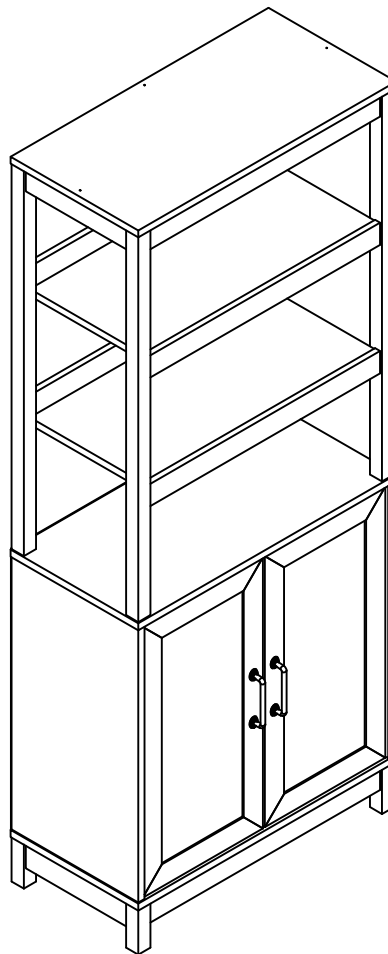

Do Not Return This Product!
Contact our customer service team for help first.
Call: 1-800-489-3351 (toll free)
Visit: www.ameriwoodhome.com

THIS INSTRUCTION BOOKLET CONTAINS **IMPORTANT** SAFETY INFORMATION. PLEASE READ AND KEEP FOR FUTURE REFERENCE.

Secure Your Furniture

Keep your home and family safe with the wall anchor kit that is included with the product.

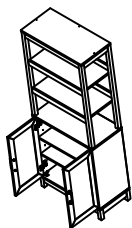

Serious or fatal crushing injuries can occur from tipping furniture.

WARNING: Manufacturer assumes no liability for improper installation or excessive loads placed on screws or bracket. This wall anchor is not a substitute for proper adult supervision.



Follow Ameriwood Home



Contact Us!

Do NOT return this product!

Contact our friendly customer service team first for help.



Visit ameriwoodhome.com to view the limited warranty valid in the U.S. and Canada.

Assembly Tips



Helpful Hints

PEOPLE NEEDED FOR ASSEMBLY: 1-2

- Open your item in the area you plan to keep it to avoid excessive heavy lifting.
- Identify, sort and count the parts before attempting assembly.
- Compression dowels are lightly tapped in with a hammer.
- Slides are labeled with a **R** (right) and **L** (left) for proper placement.
- Make sure to always face the point on the top of the Cam Lock towards the outer edge.
- Use all the nails provided for the back panel and spread them out equally.
- Back panel must be used to make sure your unit is sturdy.
- Do NOT use harsh chemicals or abrasive cleaners on this item.
- Never push, pull, or drag your furniture.



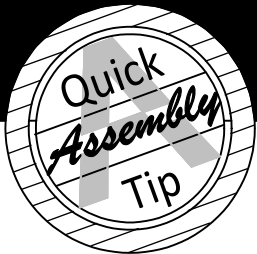

Before You Start



- ✓ Read through each step carefully and follow the proper order
- ✓ Separate and count all your parts and hardware
Parts are labeled on the surface or edge of the part
- ✓ Give yourself enough room for the assembly process
- ✓ Have the following tools: Flat Head Screwdriver, #2 Phillips Head Screwdriver and Hammer
- ✓ Caution: If using a power drill or power screwdriver for screwing, please be aware to slow down and stop when screw is tight. Failure to do so may result in stripping the screw.

Cam Lock Fastening System

This Cam Lock Fastening System will be used throughout the assembly process.

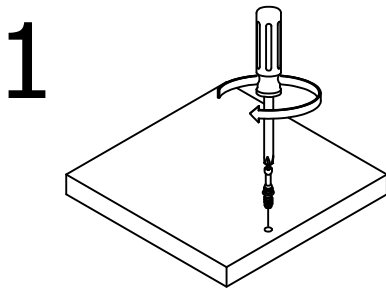

1 Screw CAM BOLT into hole.

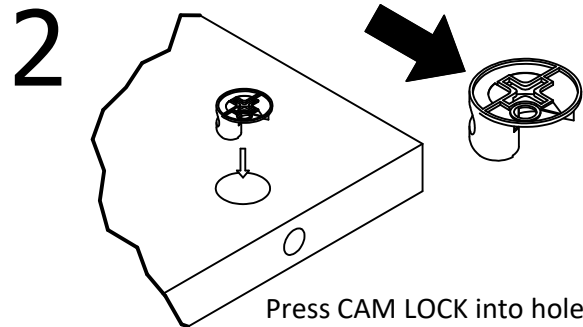

2 Press CAM LOCK into hole.

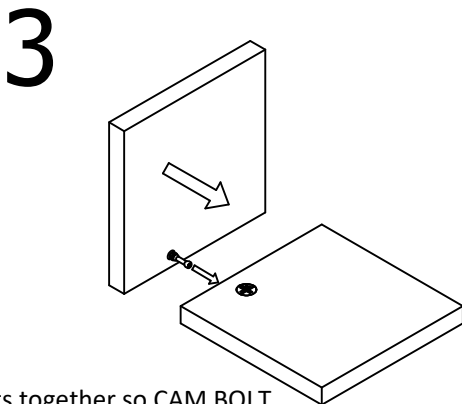

3 Press parts together so CAM BOLT inserts into edge hole.

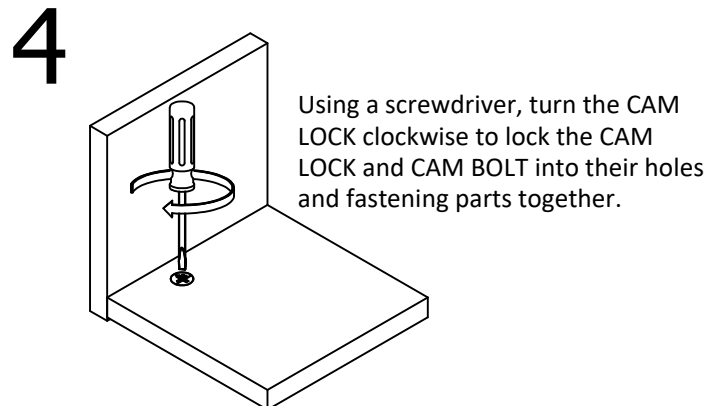

4 Using a screwdriver, turn the CAM LOCK clockwise to lock the CAM LOCK and CAM BOLT into their holes and fastening parts together.

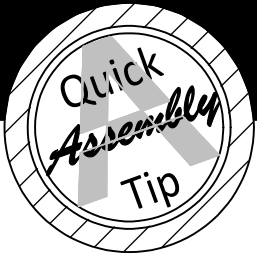

Before You Start

Please Note:

You may need to lightly tap the wood dowels into the holes during your assembly process.

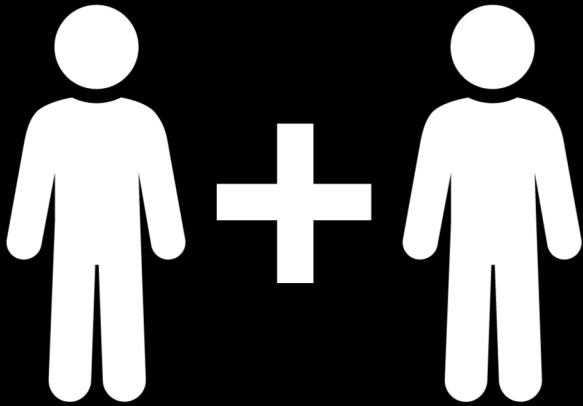
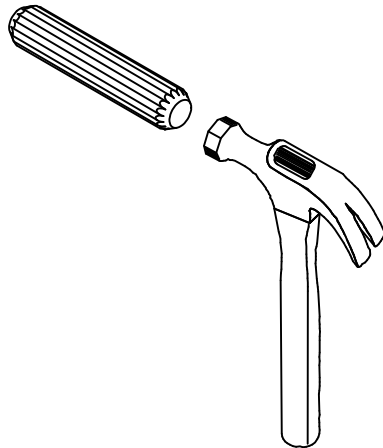

2 PEOPLE NEEDED FOR ASSEMBLY

**2 PERSONAS NECESITADAS
PARA LA ASAMBLEA**

**2 PERSONNES NÉCESSAIRES
POUR L'ASSEMBLAGE**

CAUTION: Failure to use 2 people for assembly could result in unit damage or personal injury.

PRECAUCIÓN: Si no se utilizan 2 personas para el ensamblaje, se pueden producir daños en la unidad o lesiones personales.

ATTENTION: Échec d'utiliser 2 personnes pour l'assemblage peut causer du dommage au meuble ou causer des blessures.

Board Identification

Not actual size

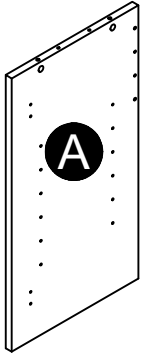

Left Panel
31614341010

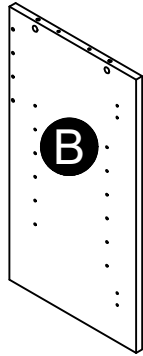

Right Panel
31614341020

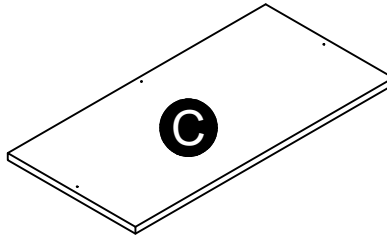

Top
31614341030

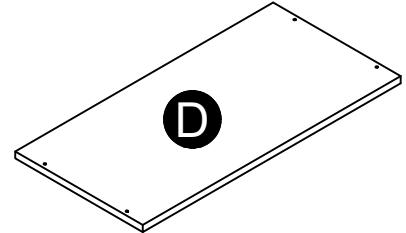

Bottom
31614341040

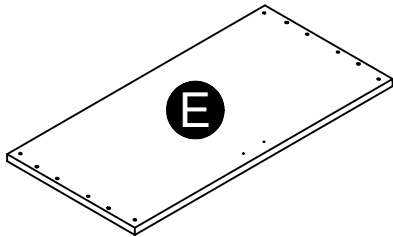

Center Shelf
31614341050

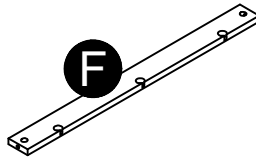

Top Rail
31614341060



Leg (x4)
35308341070

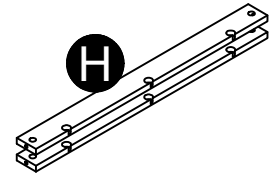

Lower Rail (x2)
35308341080

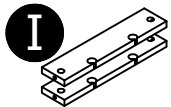

Lower Side Rail (x2)
35308341090

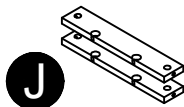

Top Side Rail (x2)
31614341100

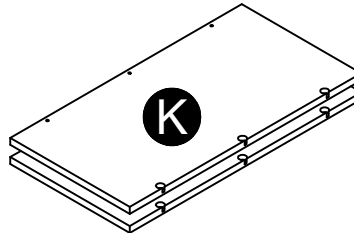

Upper Shelf (x2)
31614341110

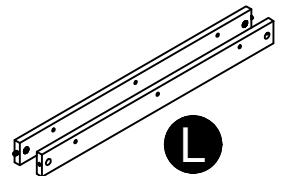

Upper Shelf Rail (x2)
31614341120

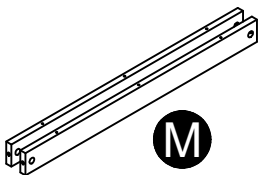

Upper Shelf Rear Rail (x2)
31614341130

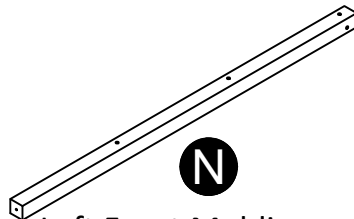

Left Front Molding
31614341140

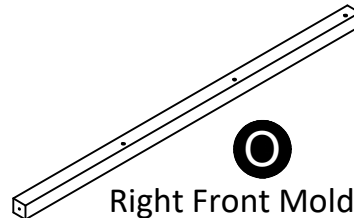

Right Front Molding
31614341150

Board Identification

Not actual size

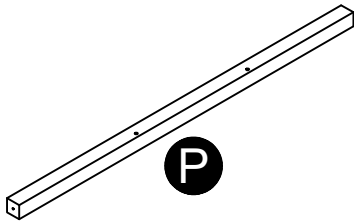

Left Rear Molding
31614341160

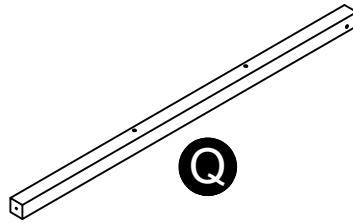

Right Rear Molding
31614341170

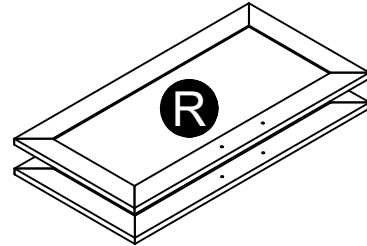

Door (x2)
31614341180

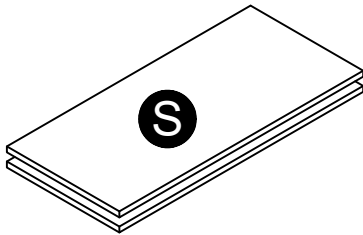

Adjustable Shelf (x2)
31614341190

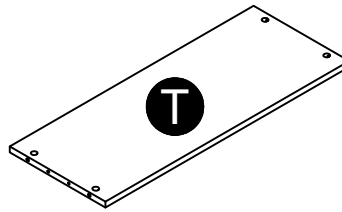

Back
31614341200

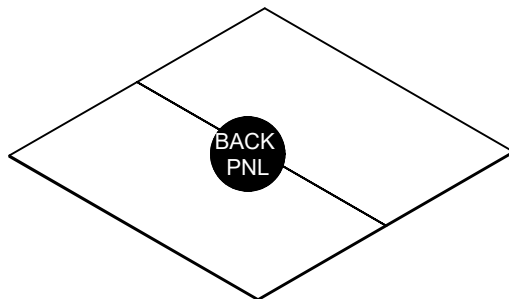

Back Panel
K161434100

This piece is paperboard construction. It is not made from wood, but is required for the assembly of your unit.

Board Identification

Not actual size

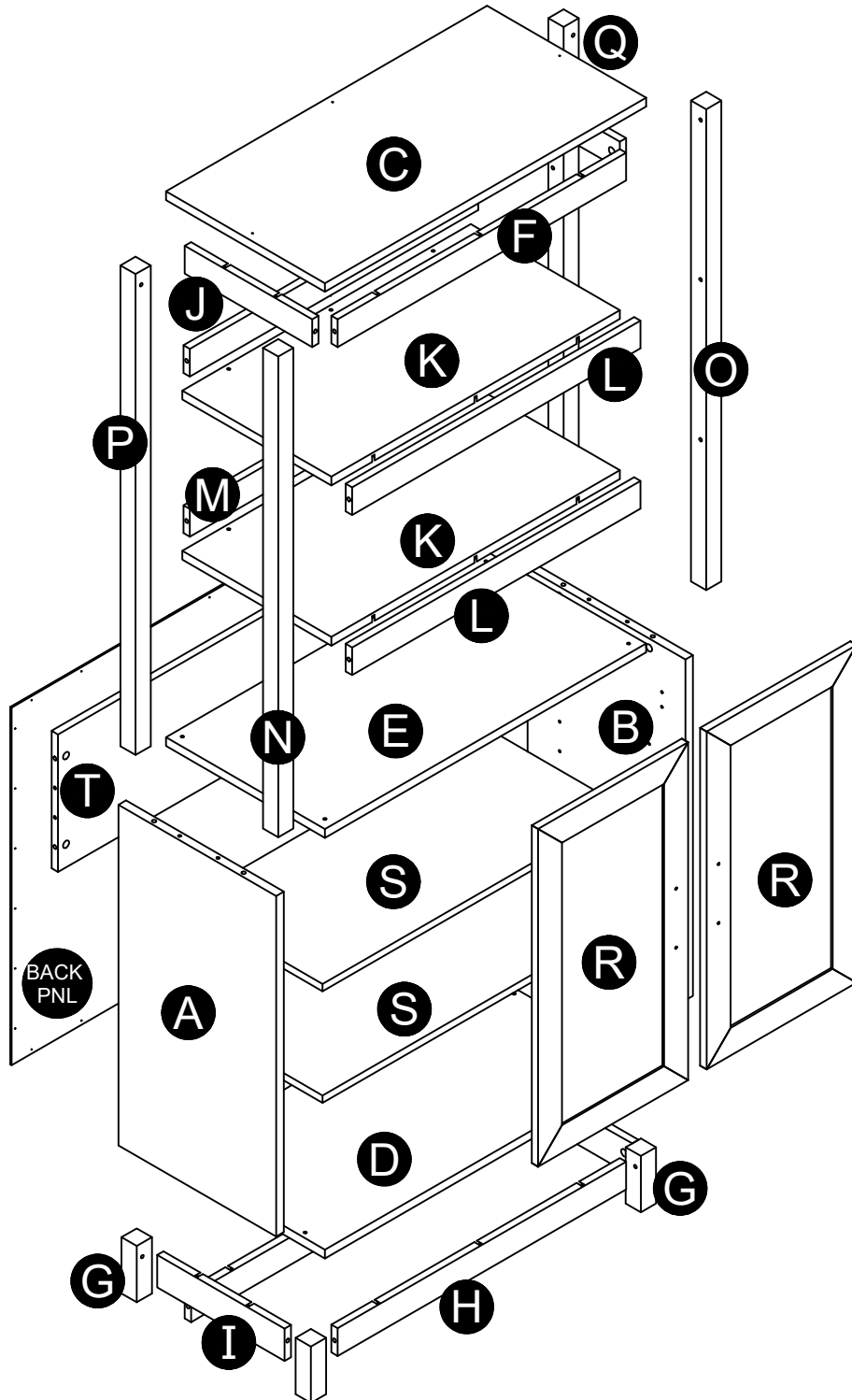

Part List

Actual Size

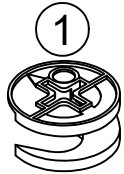

(x30)
#A22620
cam lock

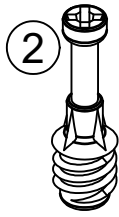

(x30)
#A22610
cam bolt



(x8)
#A21670
wood dowel

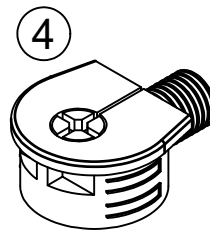

(x23)
#A22770
quickloc

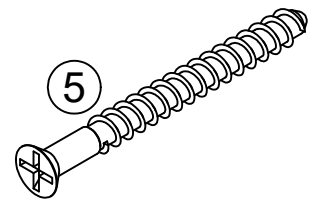

(x14)
#A23030
confirmat

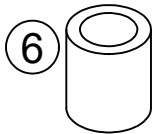

(x2)
#A89020
stop pin



(x2)
#A11170
5/8" screw

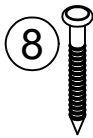

(x24)
#A21110
nail

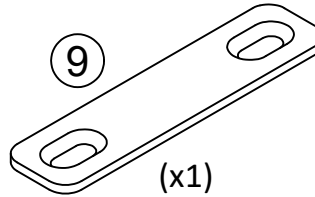

(x1)
#A53820
bracket

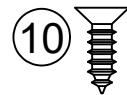

(x2)
#A11080
7/16" screw

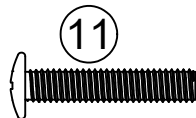

(x4)
#A17400
bolt



(x8)
#A80250
shelf support

Not Actual Size

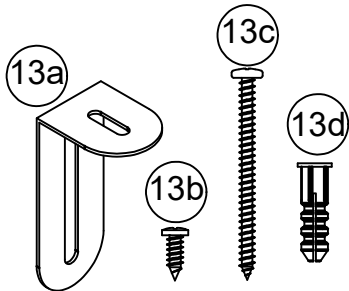

(x1)
#A84050
safety bracket

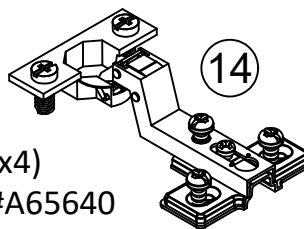

(x4)
#A65640
hinge

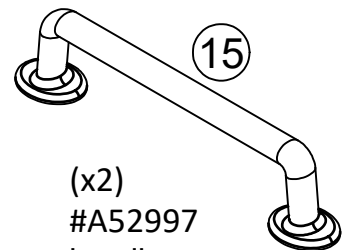

(x2)
#A52997
handle

STEP 1

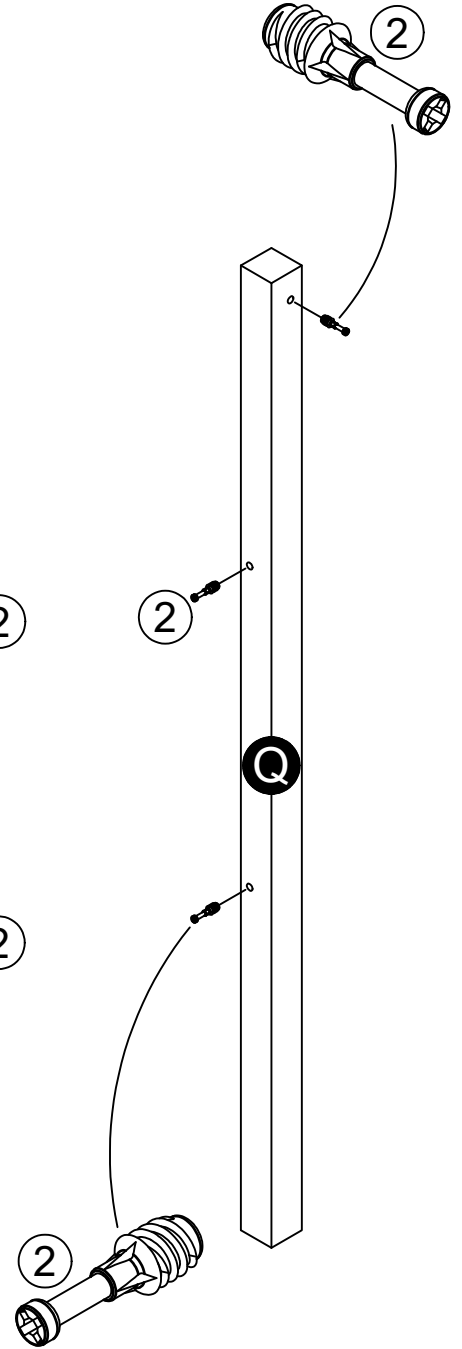
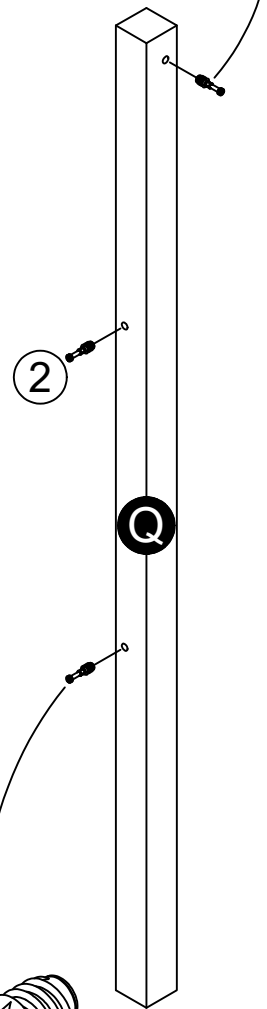
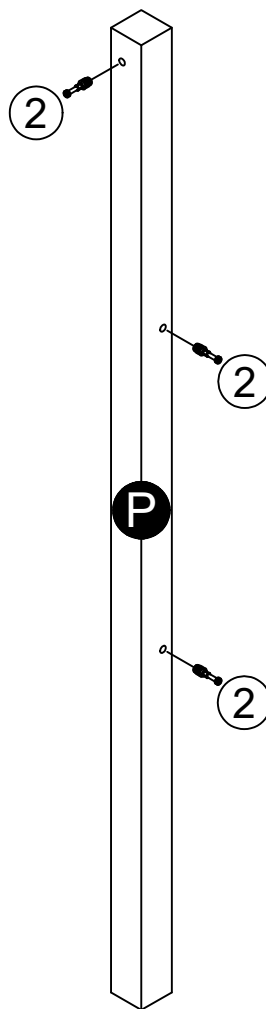
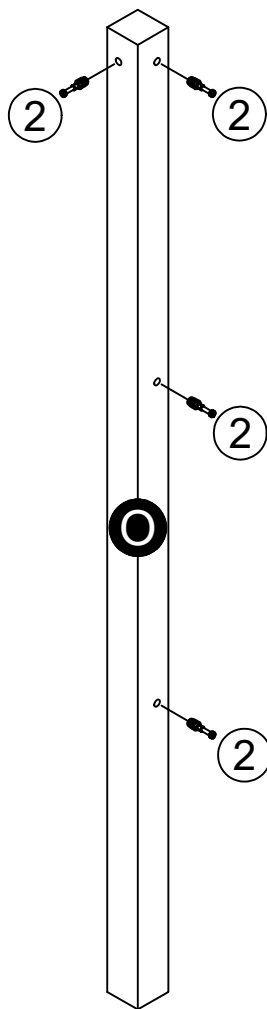
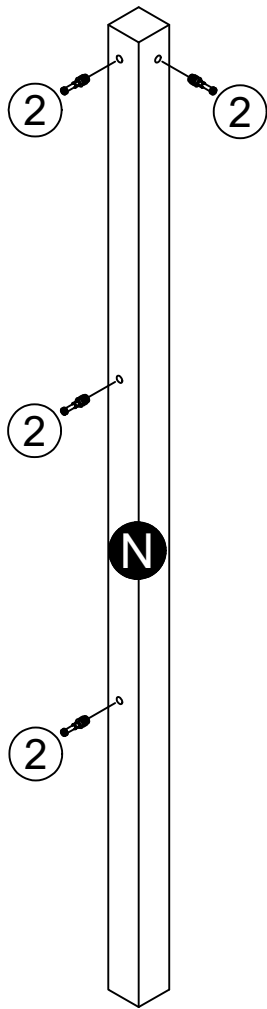
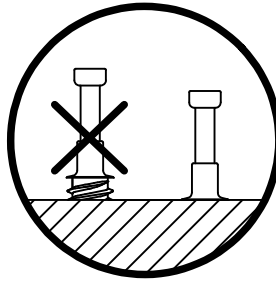
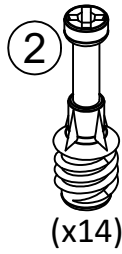
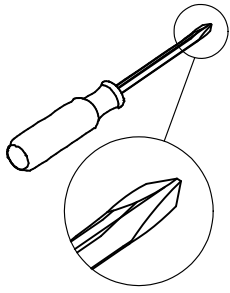

STEP 2

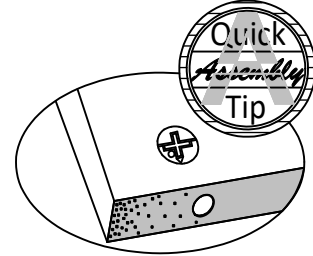
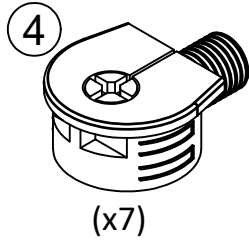

Proper orientation of CAM LOCK

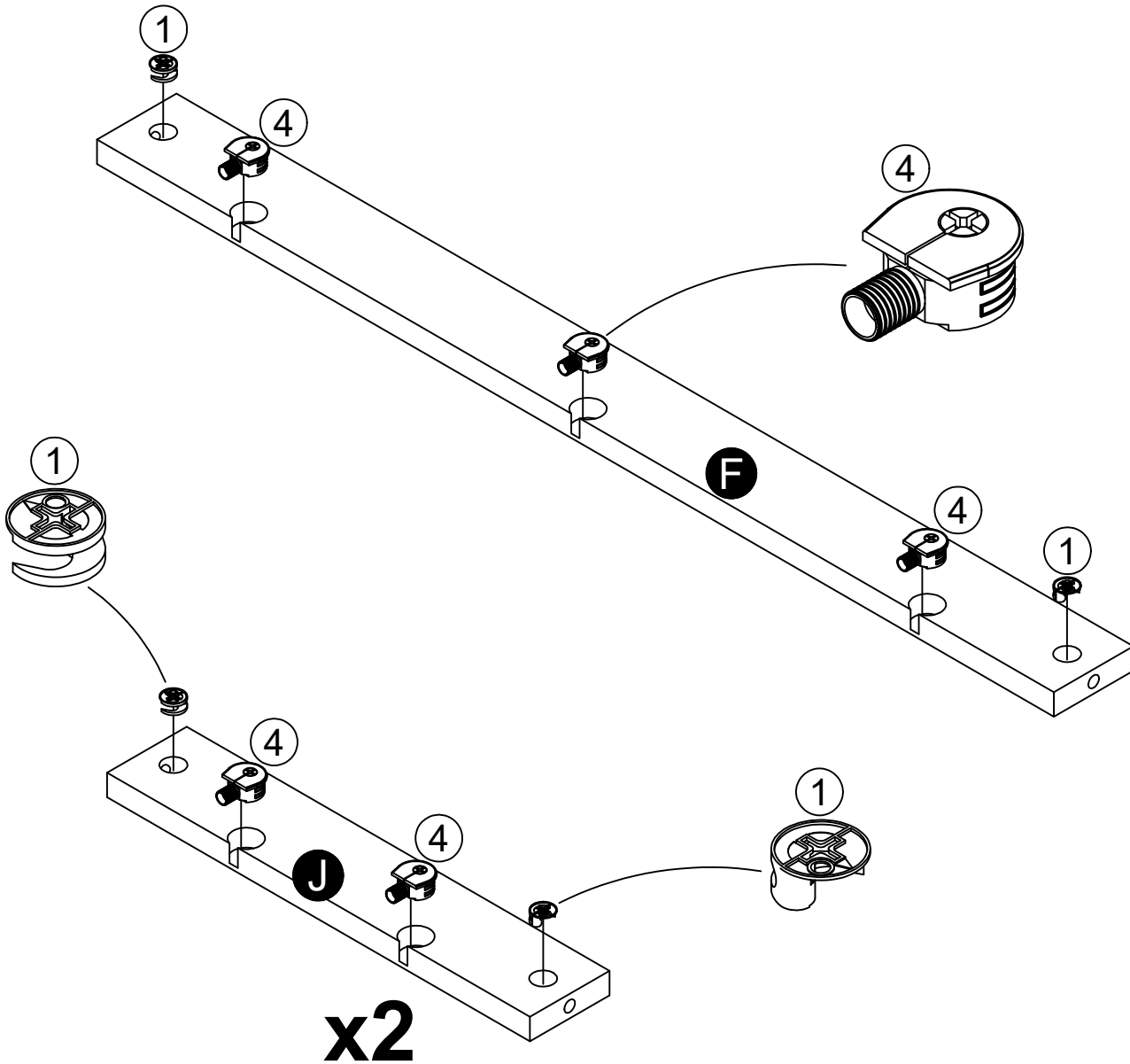

STEP 3

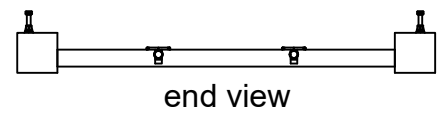
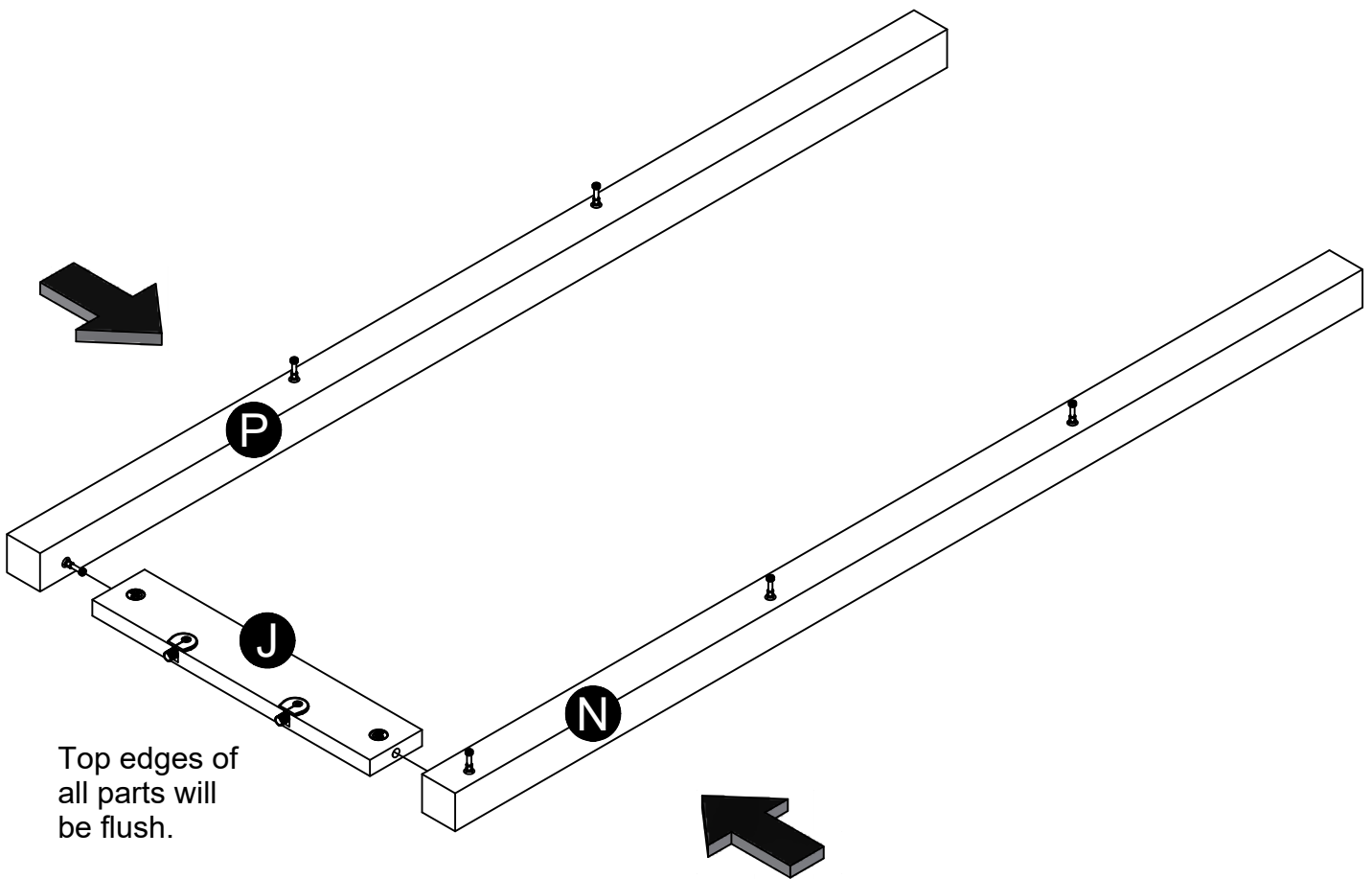
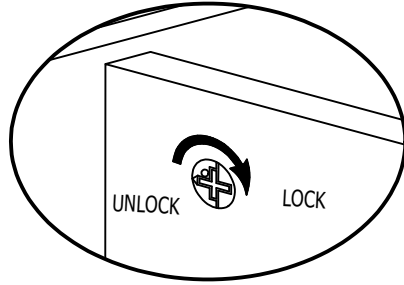
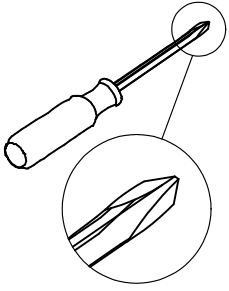

STEP 4

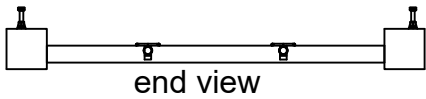
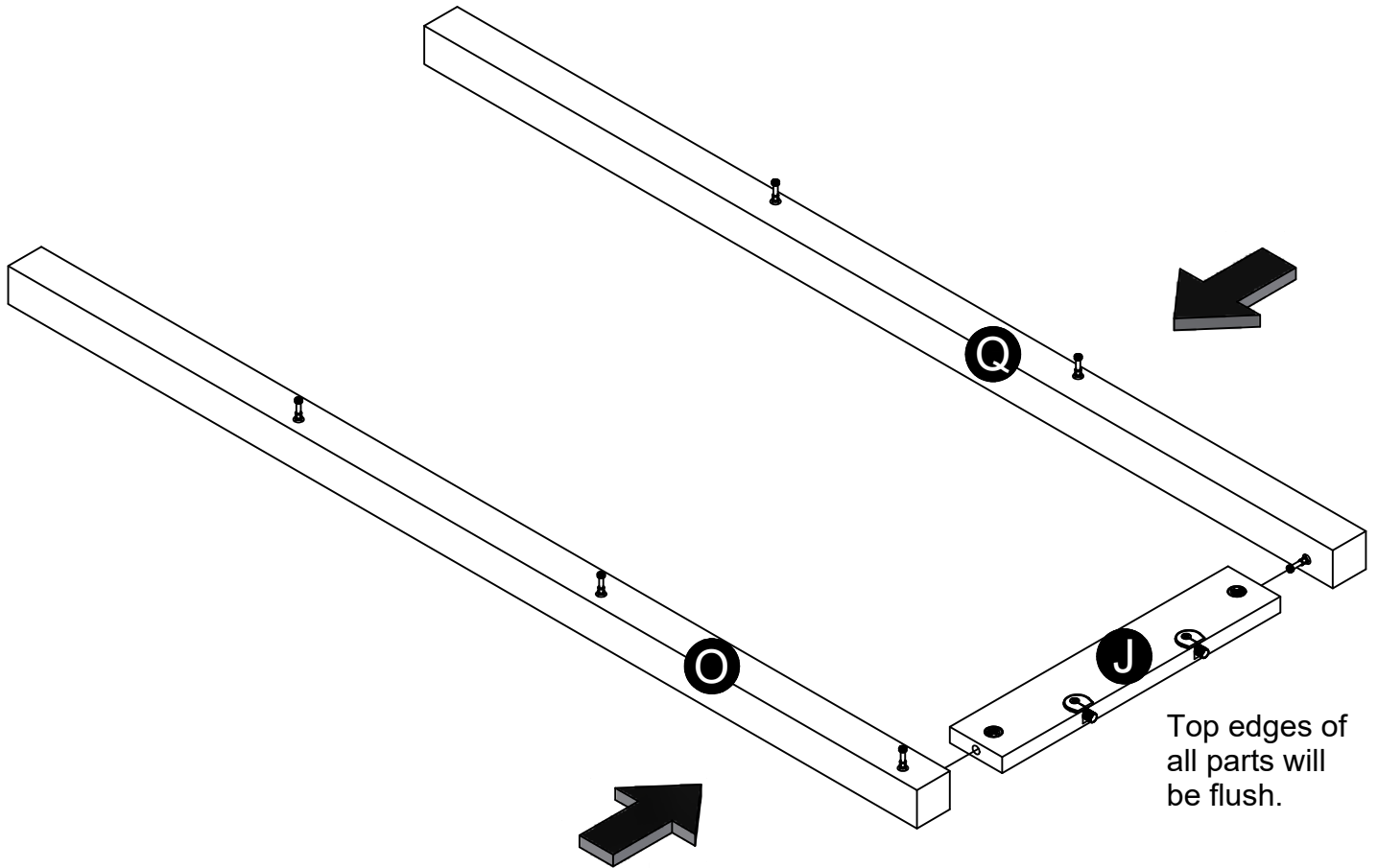
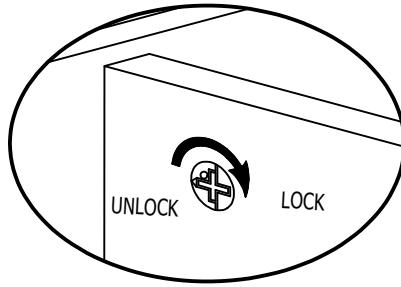
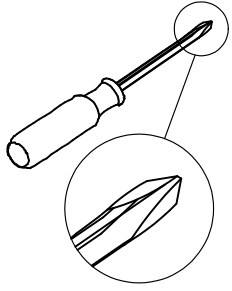

STEP 5

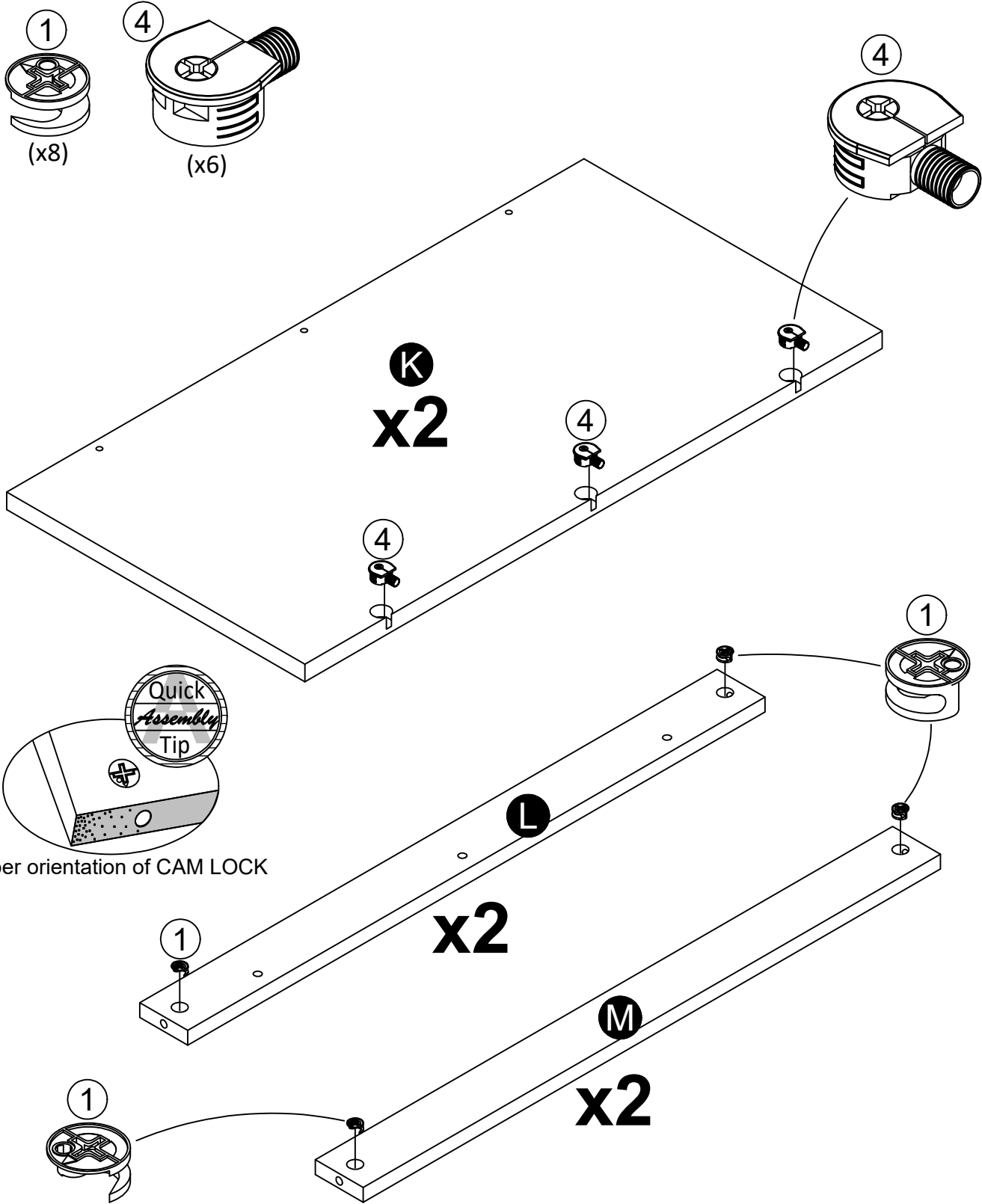

STEP 6

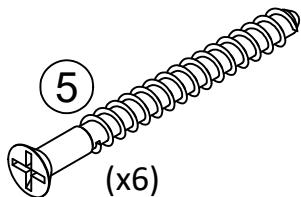
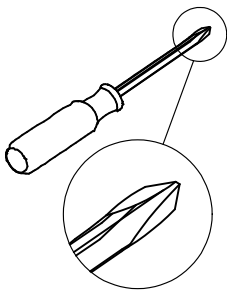

Turn screw clockwise to clamp parts together

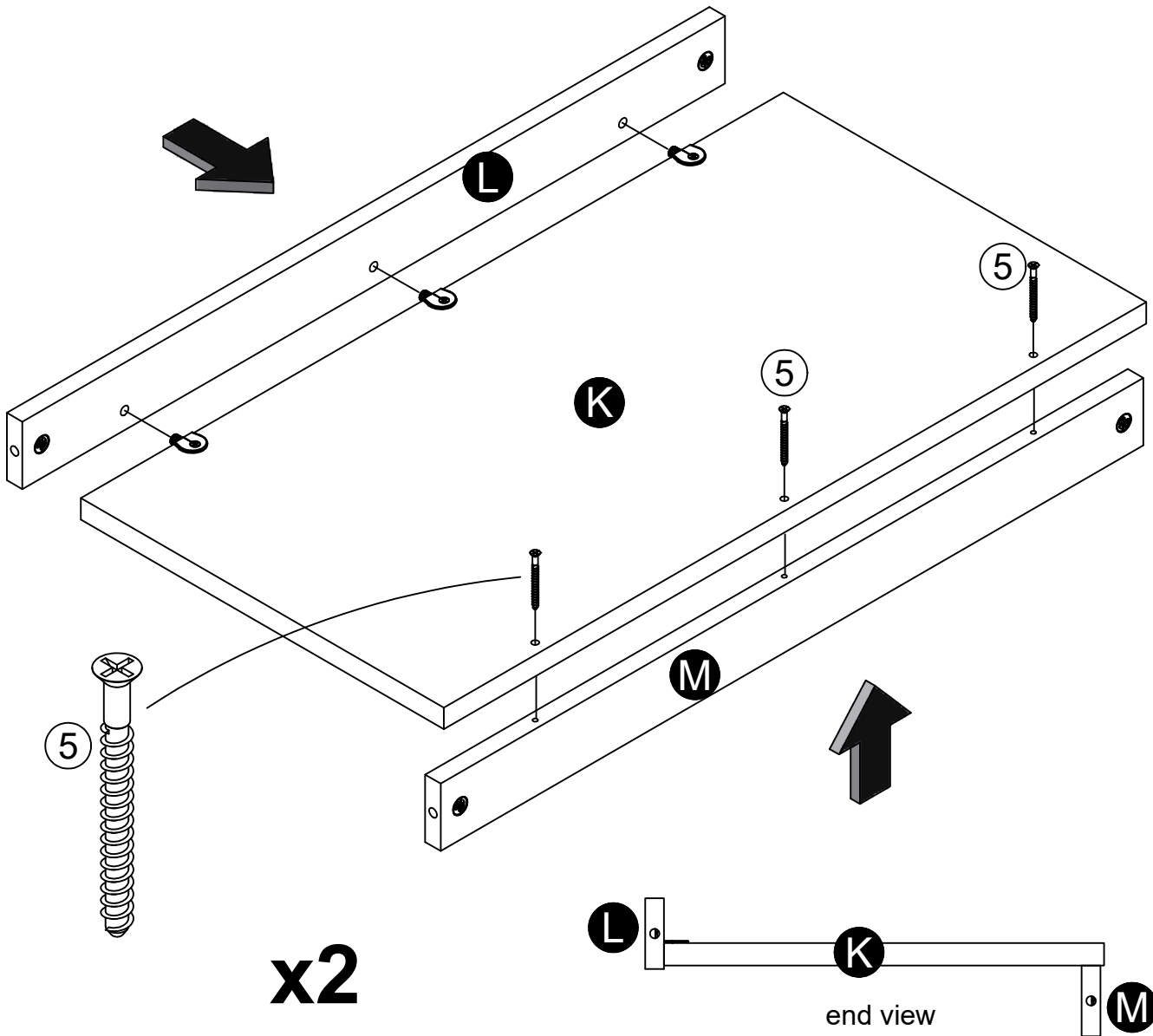
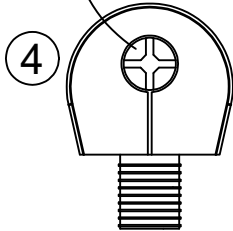

STEP 7

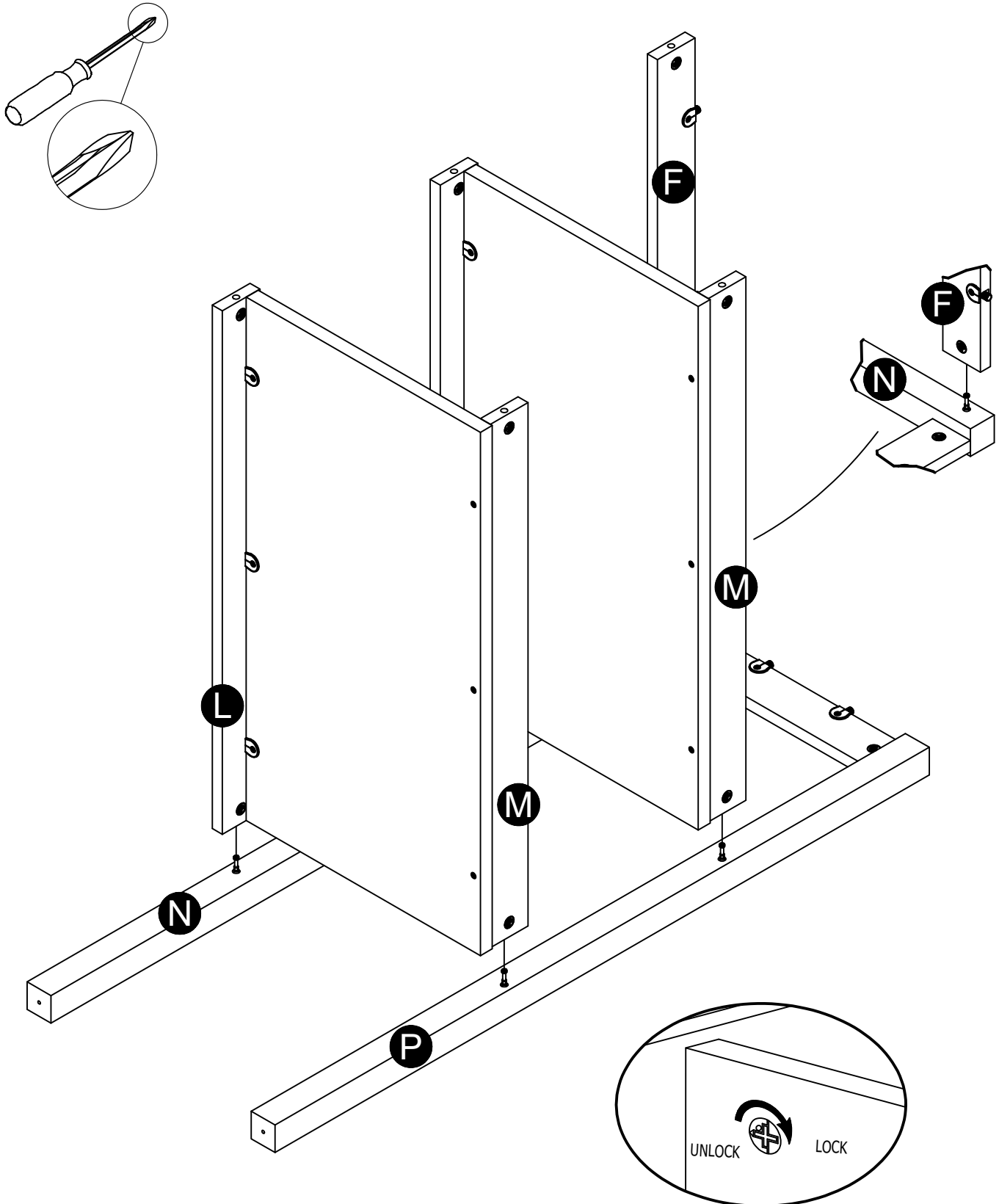

STEP 8

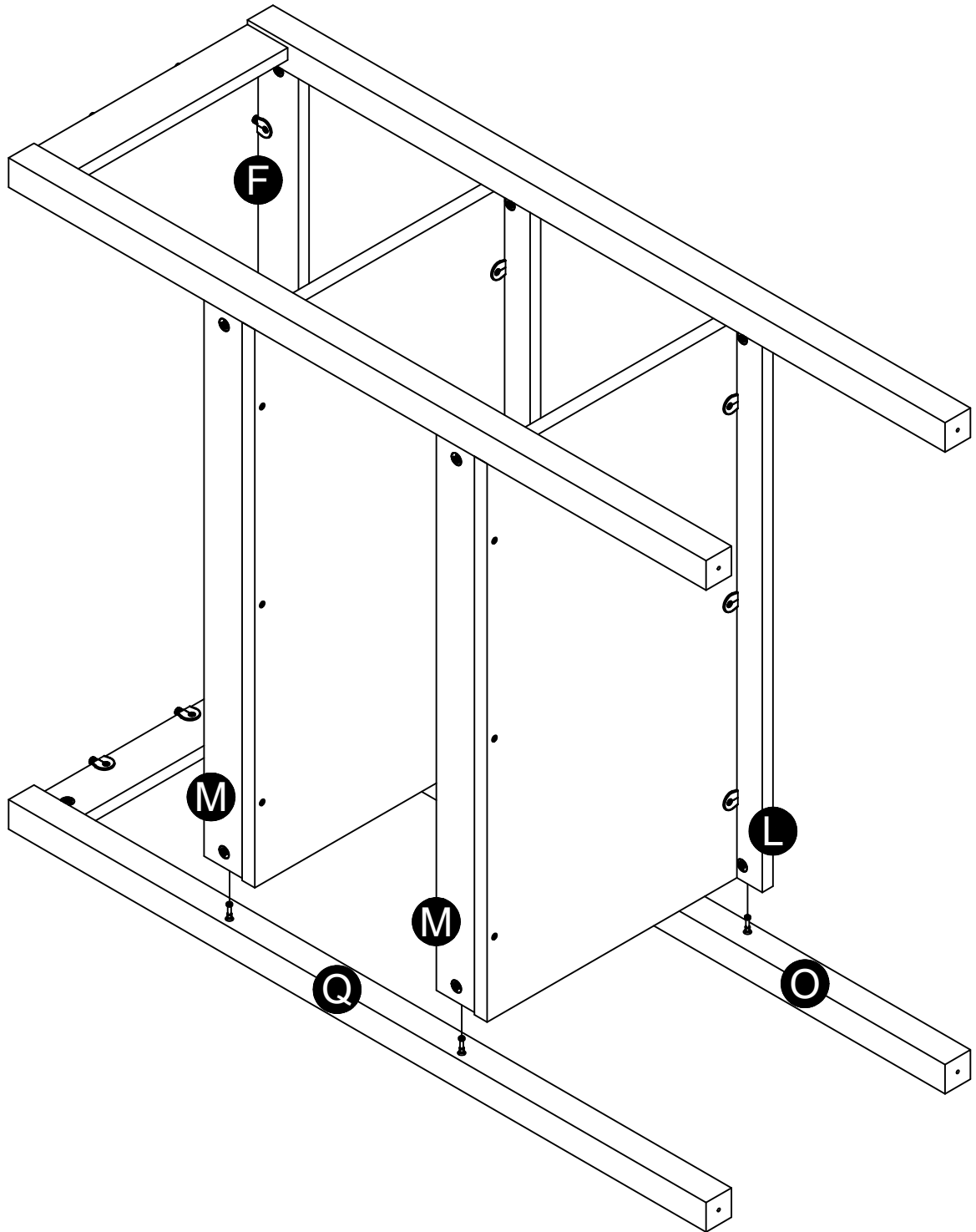

STEP 9

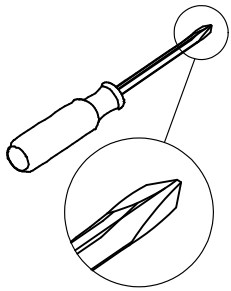

Turn screw clockwise to clamp parts together

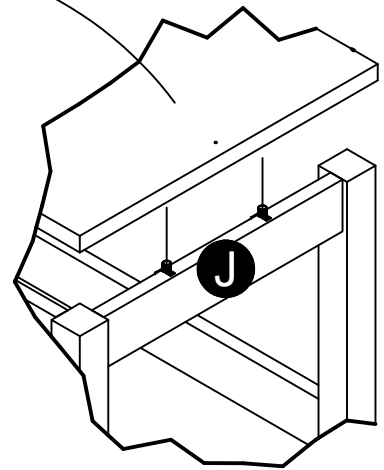
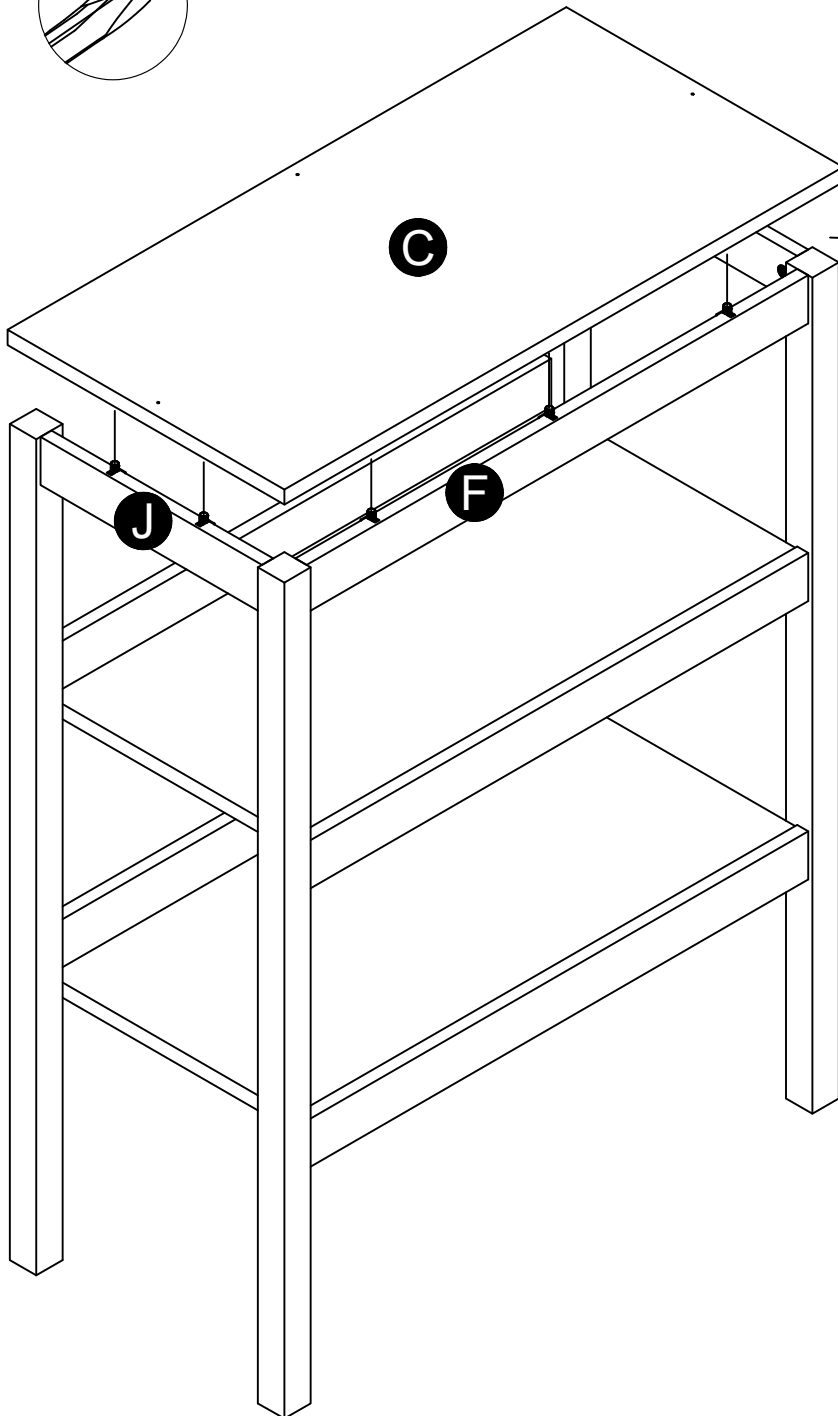
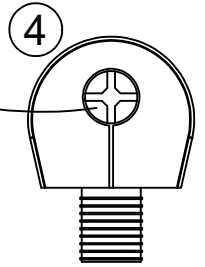

STEP 10

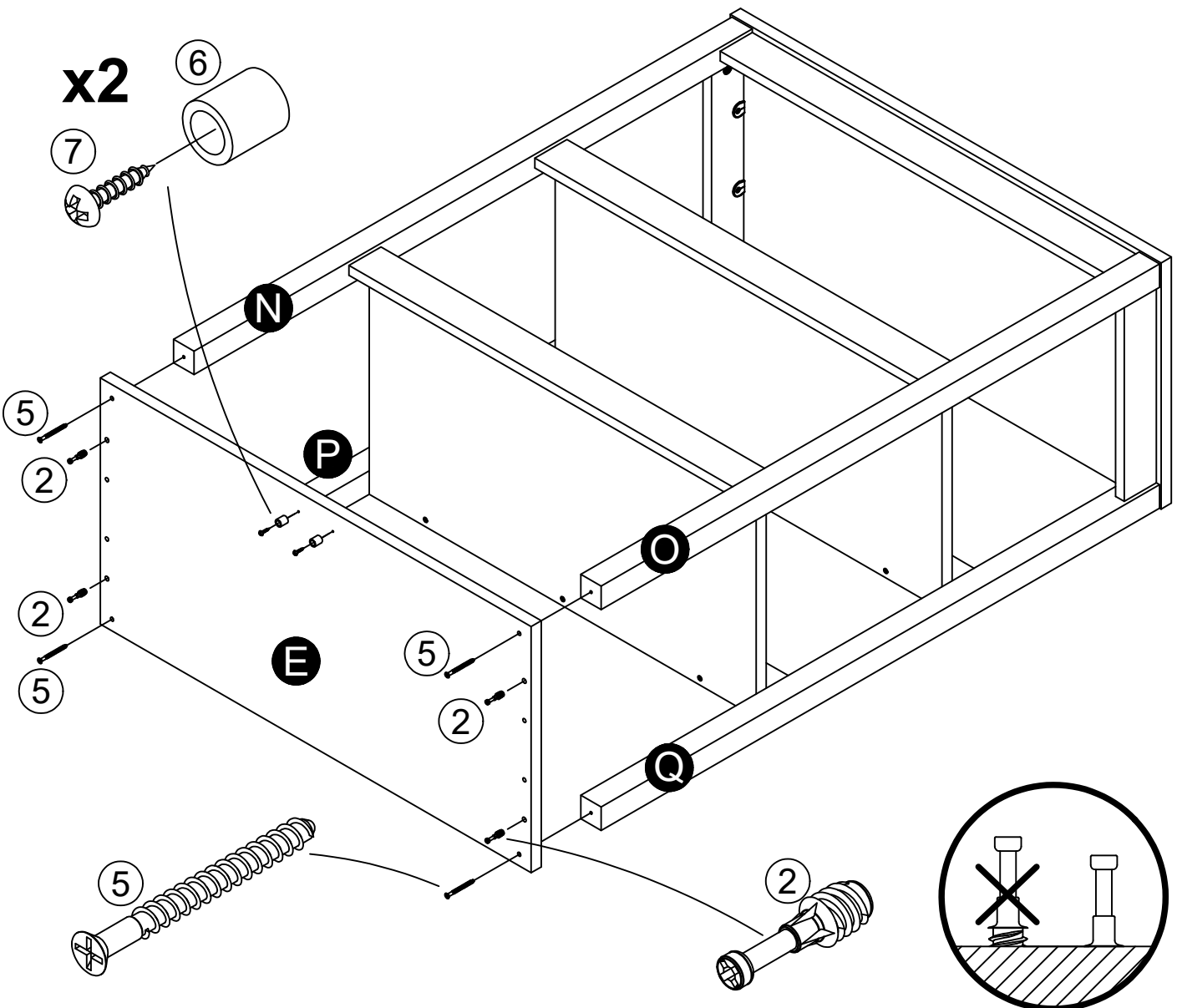
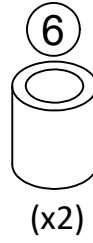
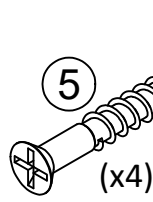
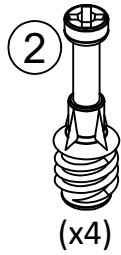
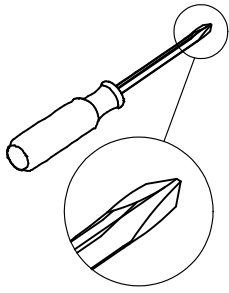

STEP 11

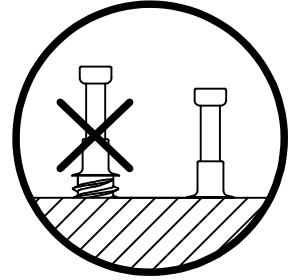
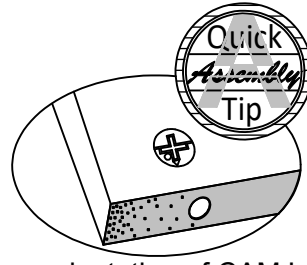
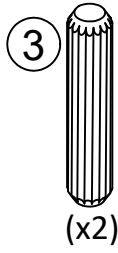
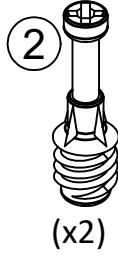
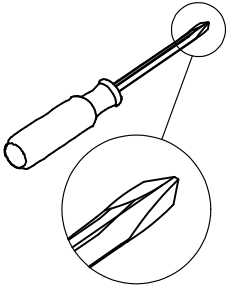

Proper orientation of CAM LOCK

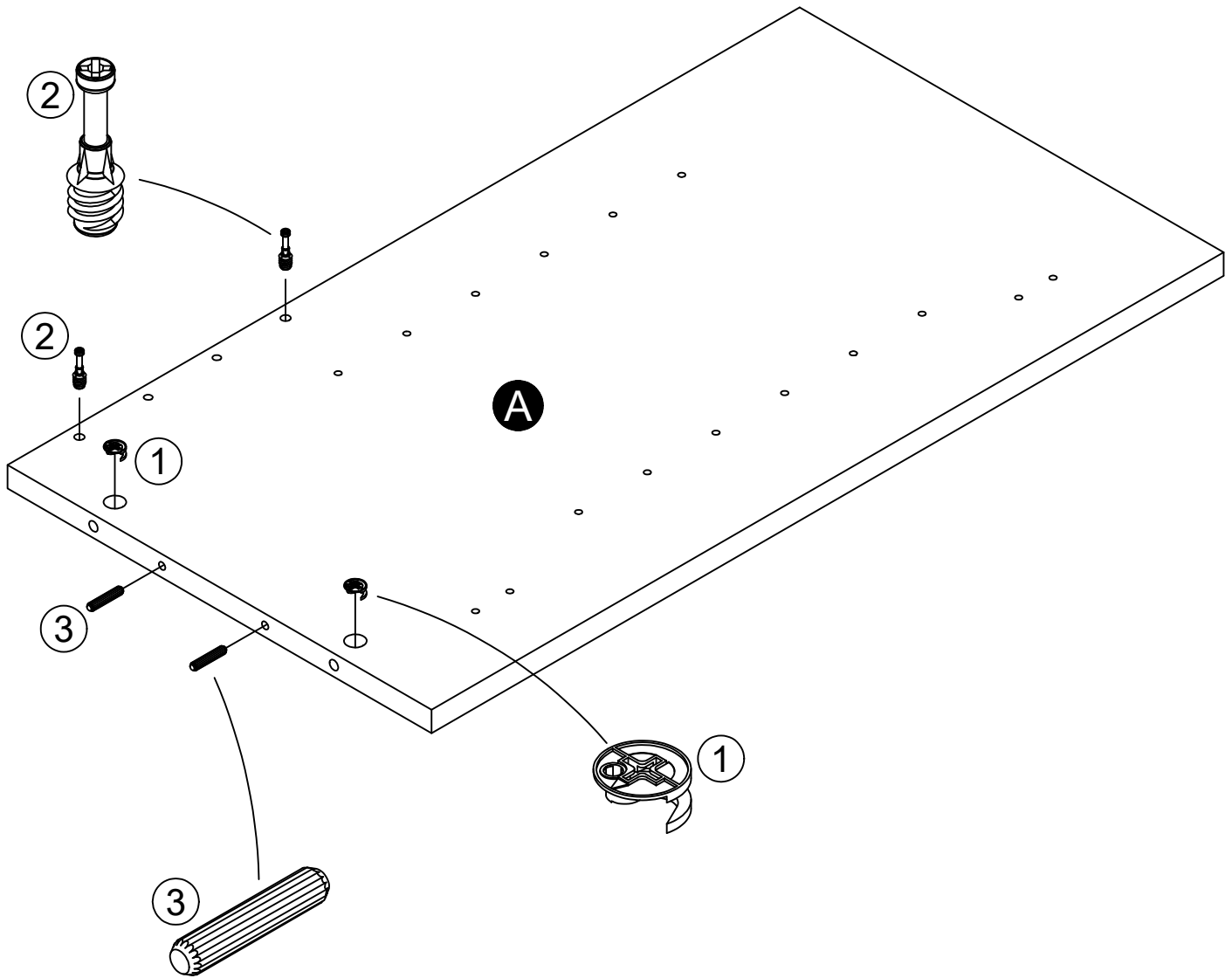

STEP 12

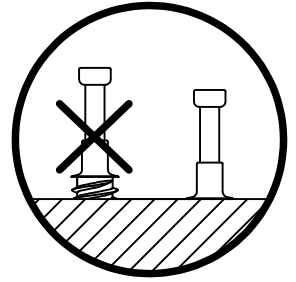
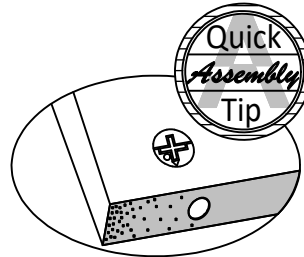
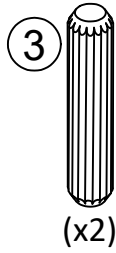
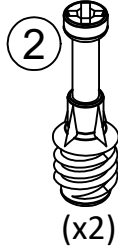
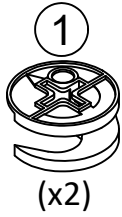
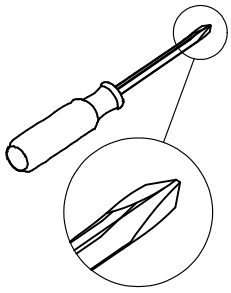

Proper orientation of CAM LOCK

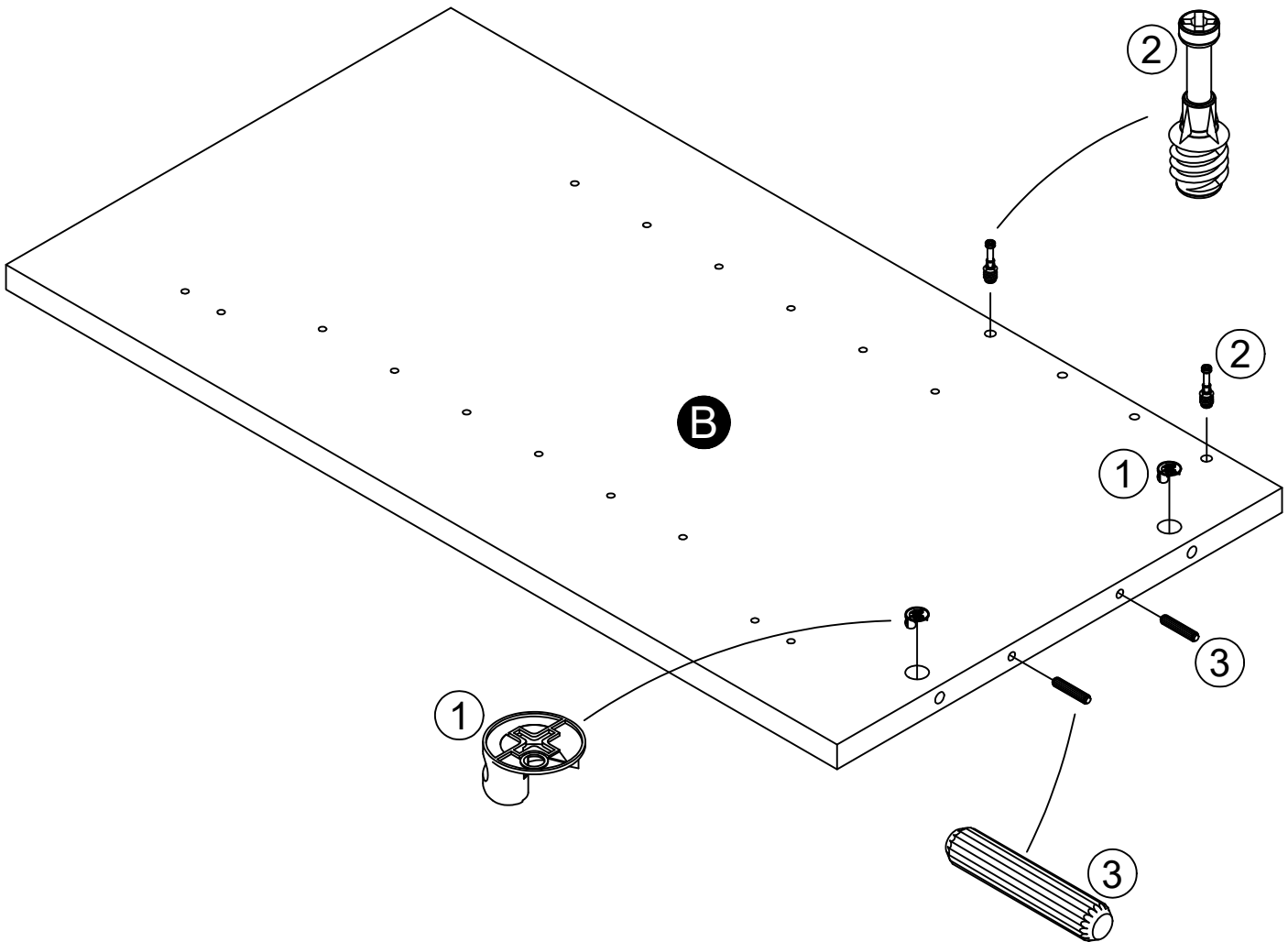

STEP 13

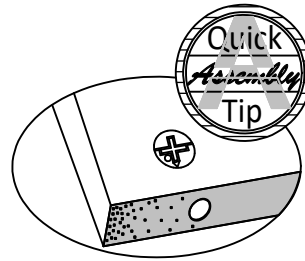
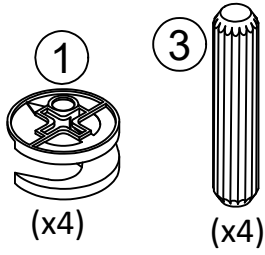

Proper orientation of CAM LOCK

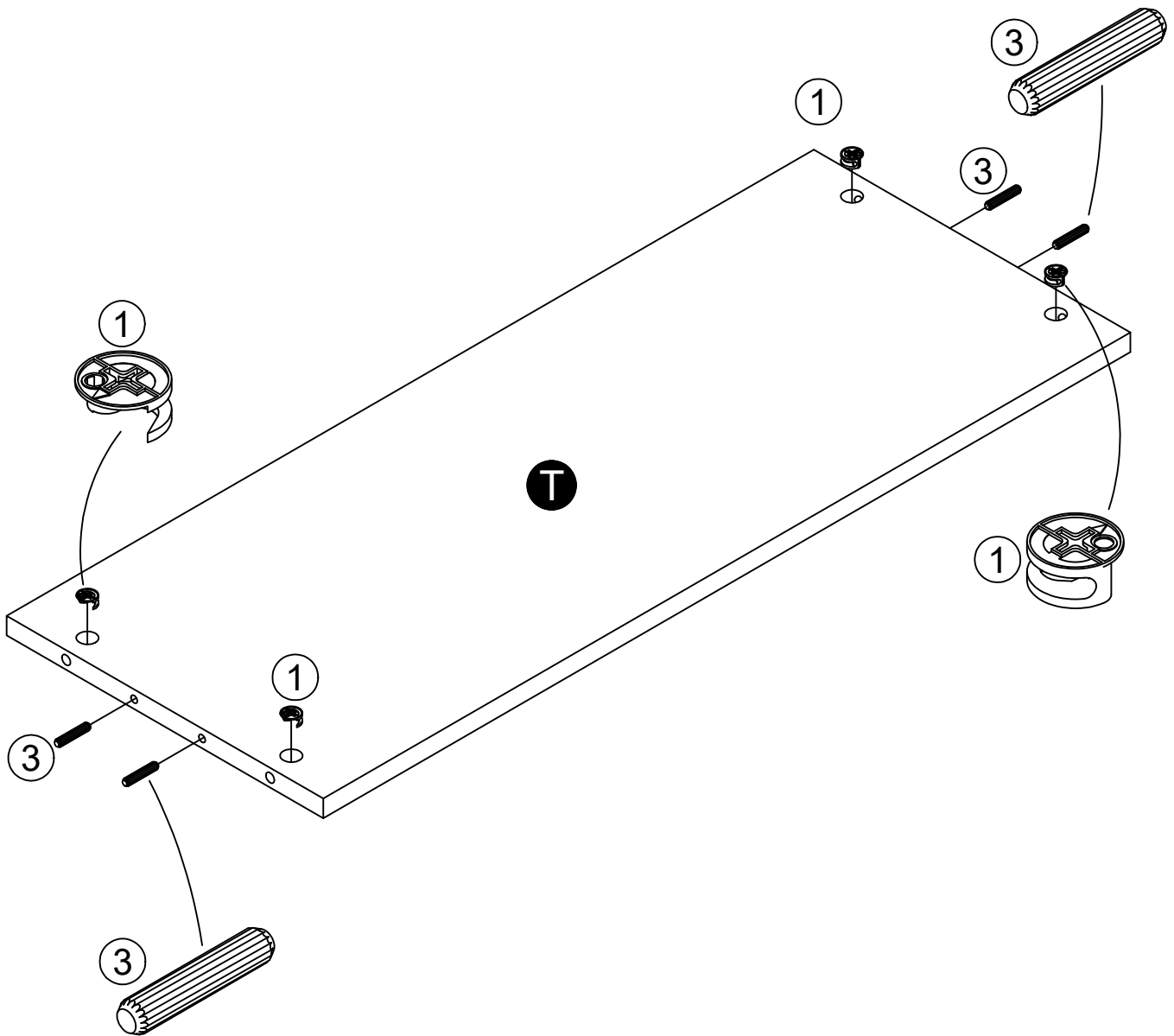

STEP 14

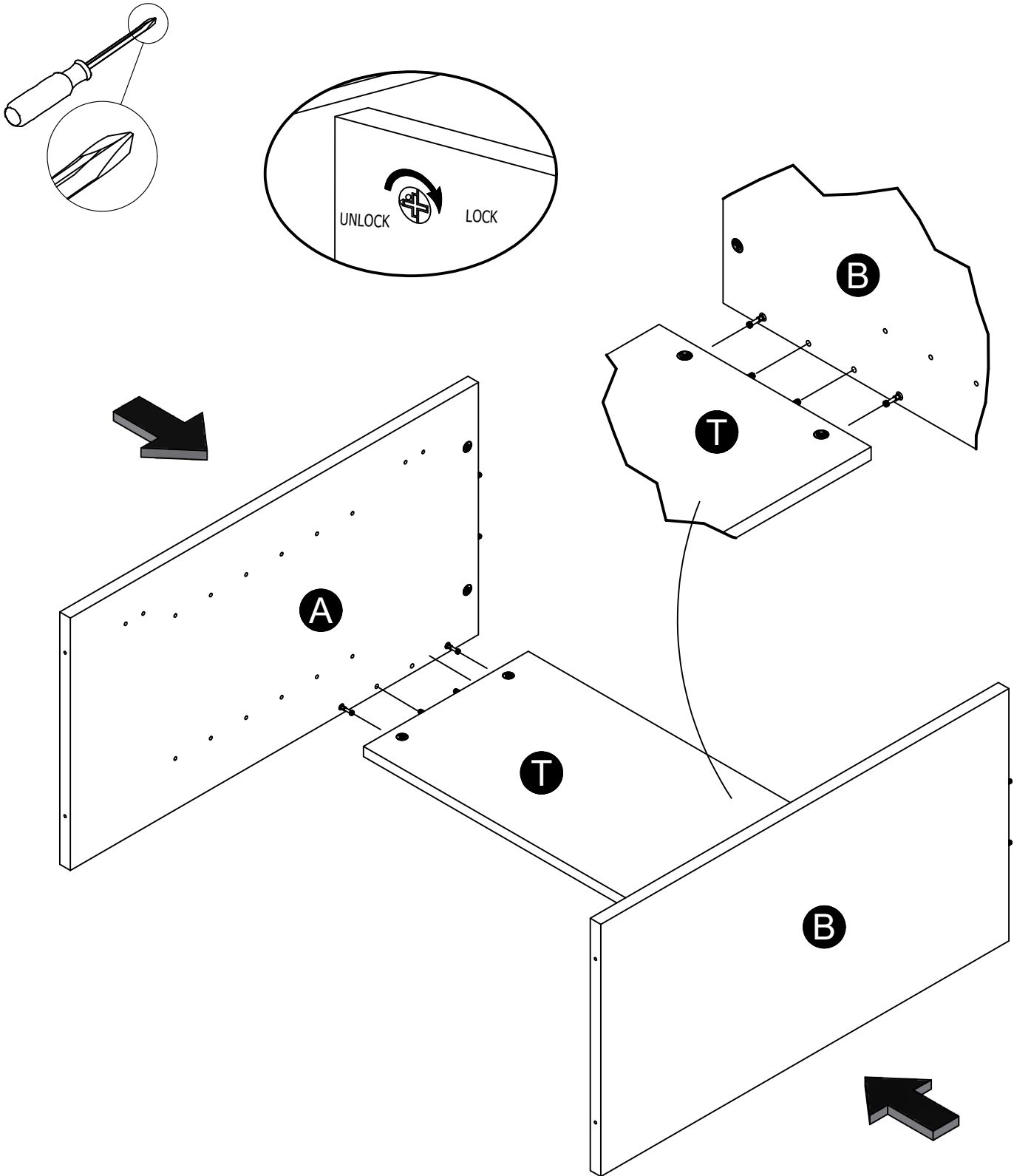

STEP 15

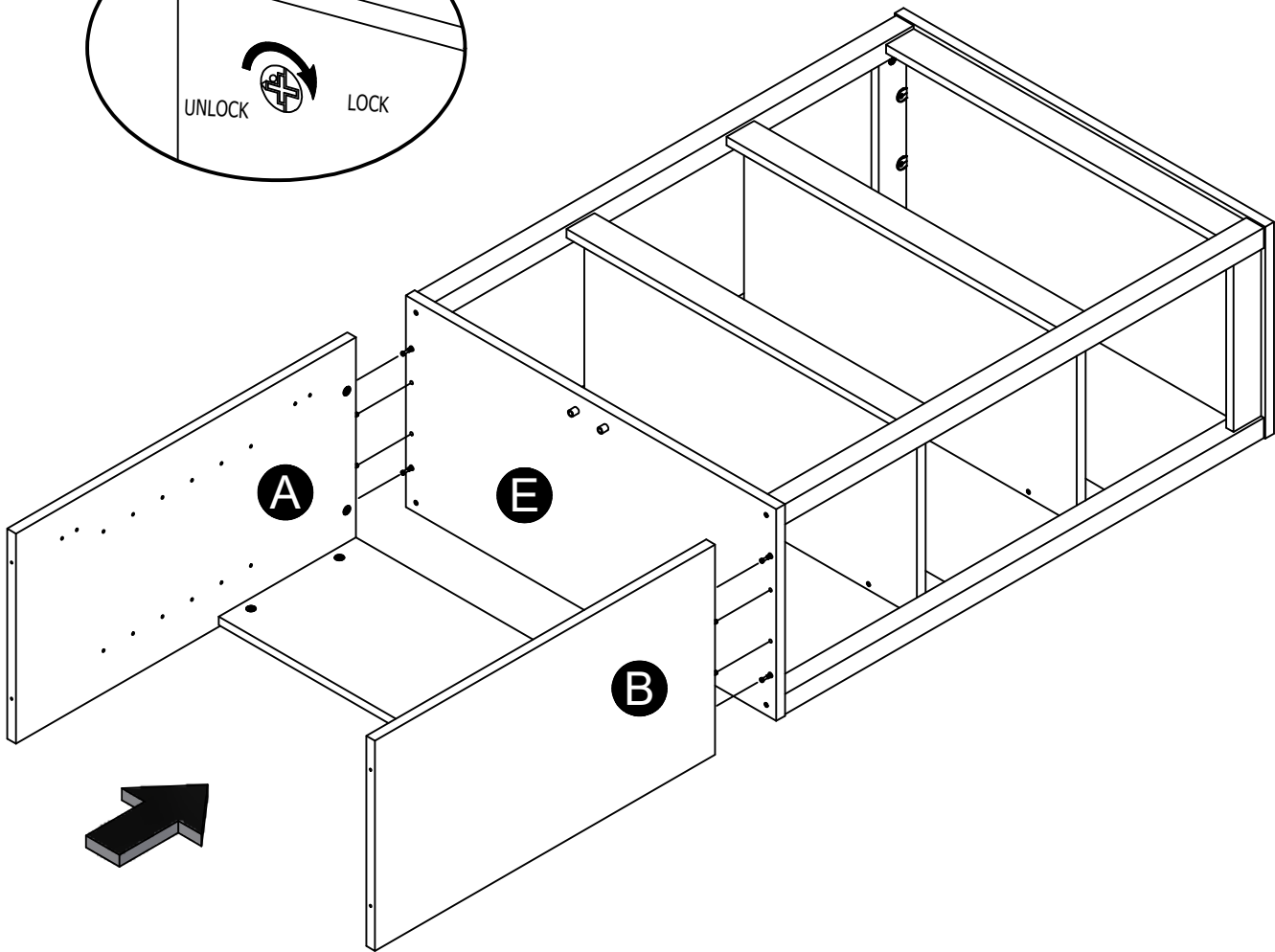
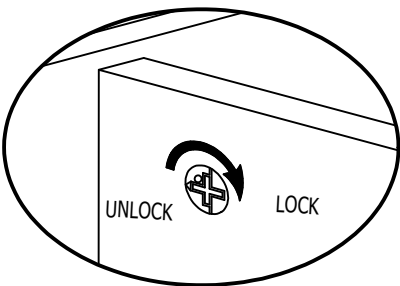
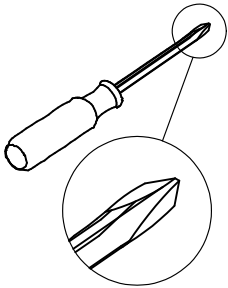

STEP 16

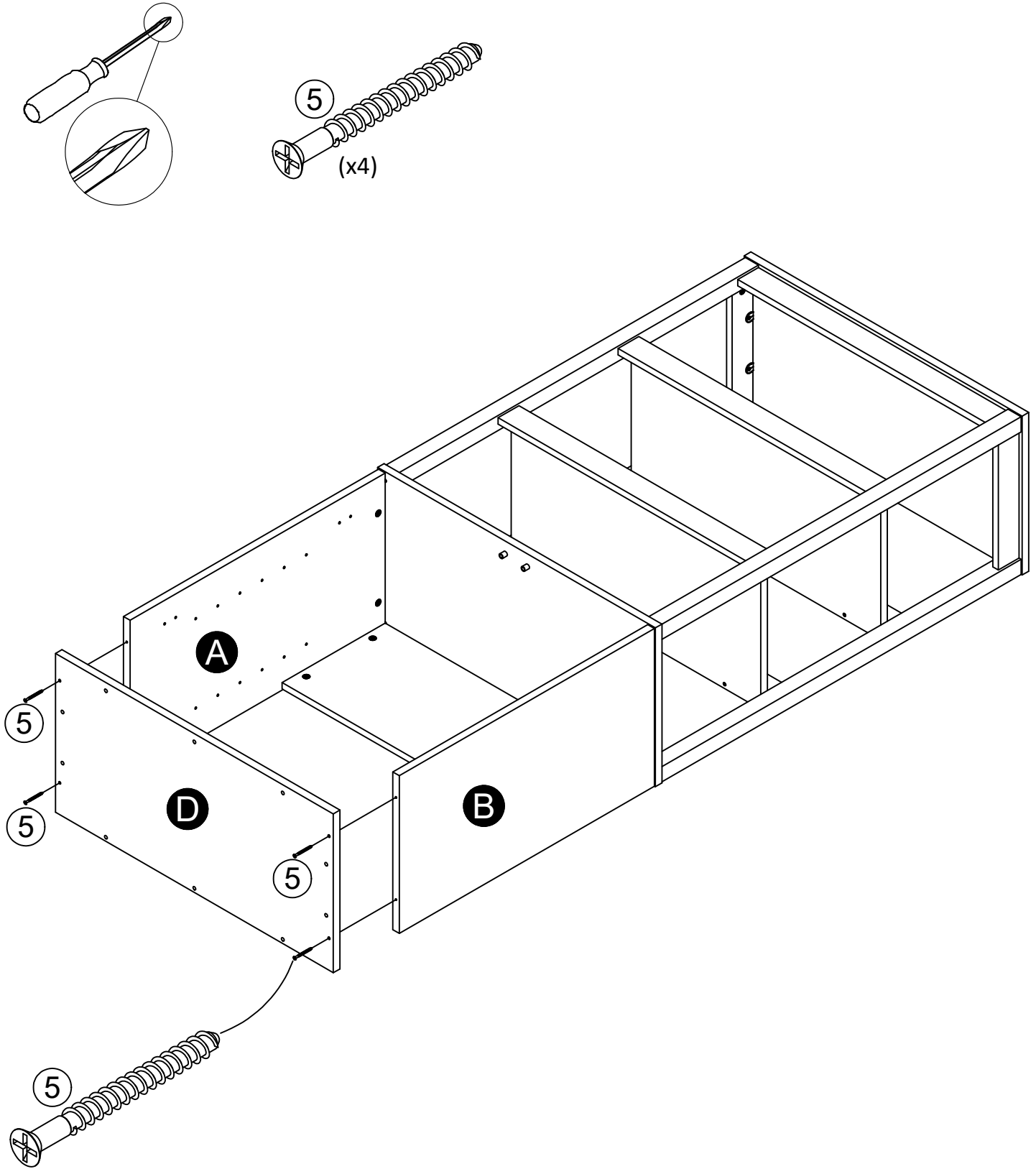

STEP 17

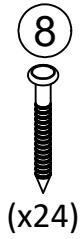
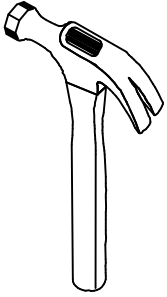

IMPORTANT! THE BACK PANEL IS A STRUCTURAL PART OF THIS UNIT AND MUST BE INSTALLED PROPERLY.

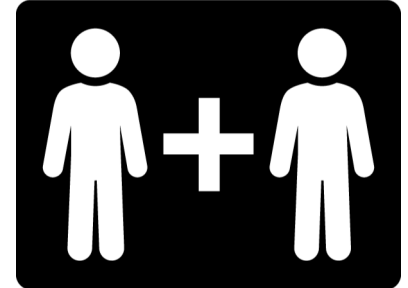

With the help of another person, turn unit onto it's front.
Attached the back panel as shown.
Nail straight into the raw edges.

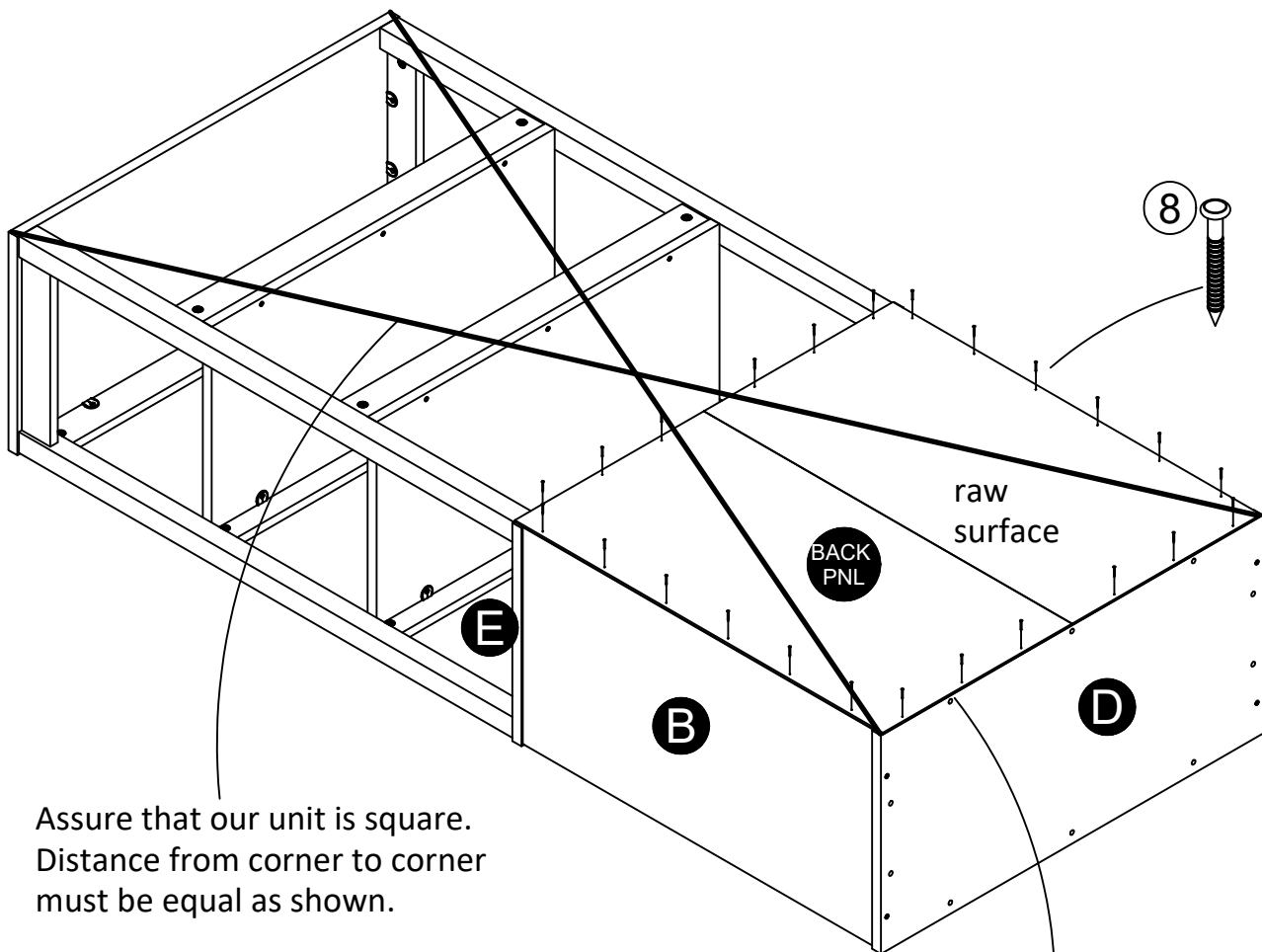

Assure that our unit is square.
Distance from corner to corner
must be equal as shown.

Flush bottom edge of the back
panel with the bottom edge of
bottom (D).

STEP 18

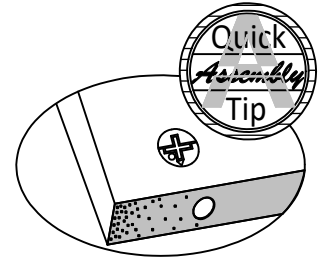
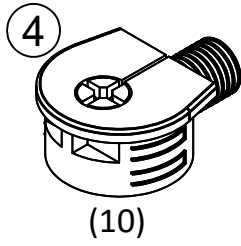

Proper orientation of CAM LOCK

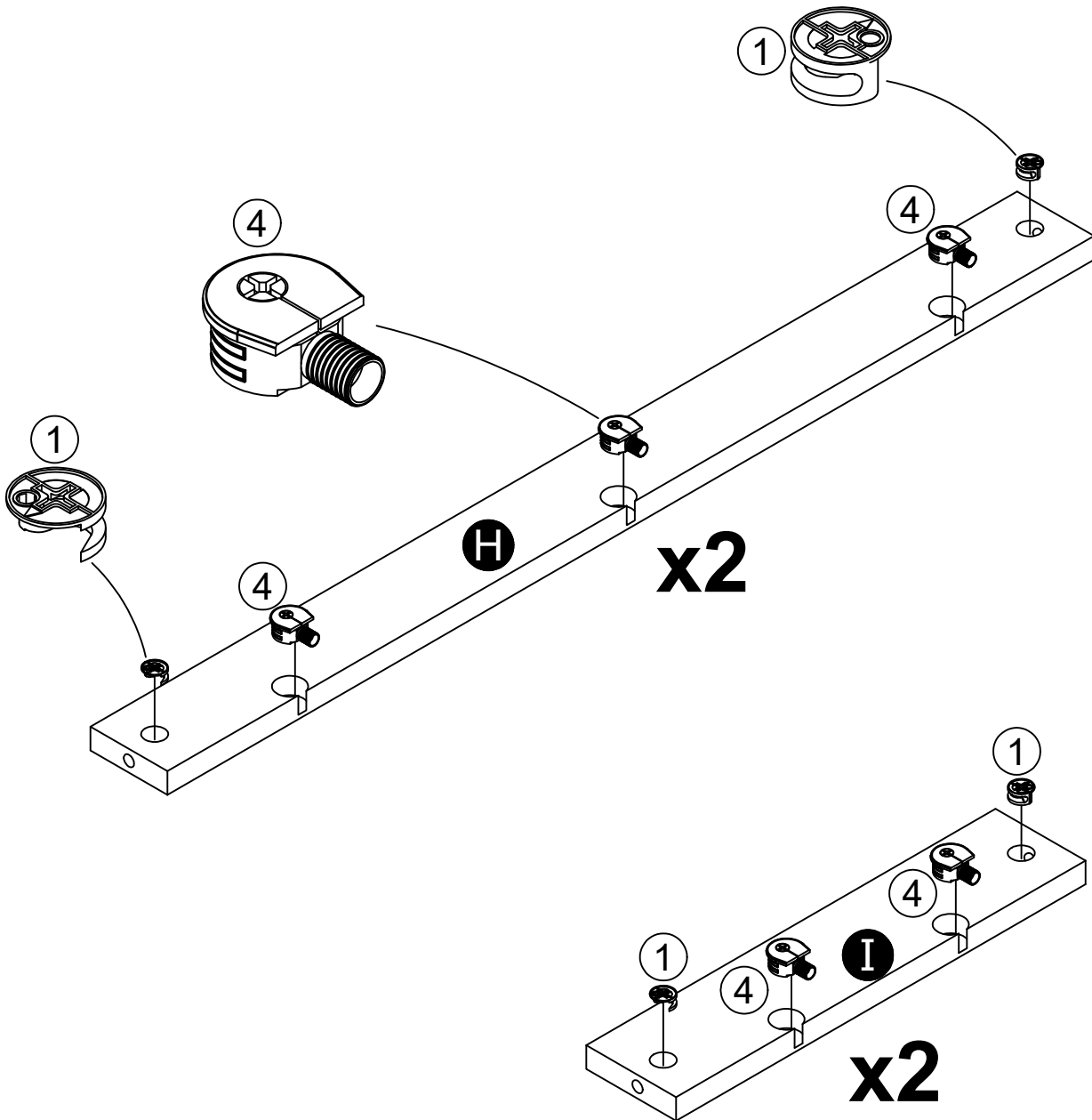

STEP 19

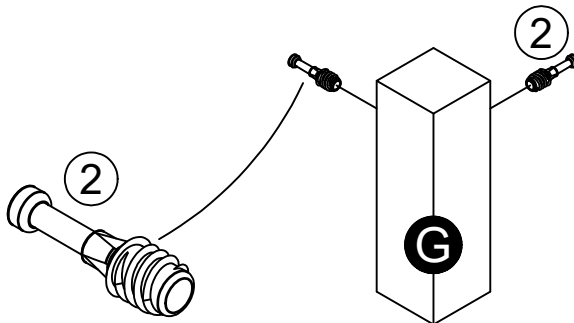
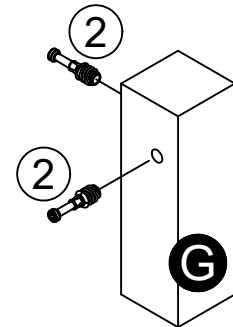
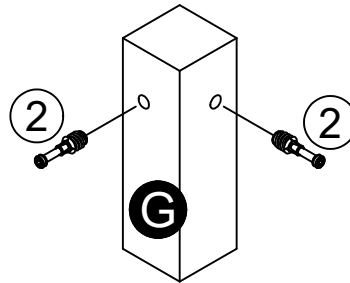
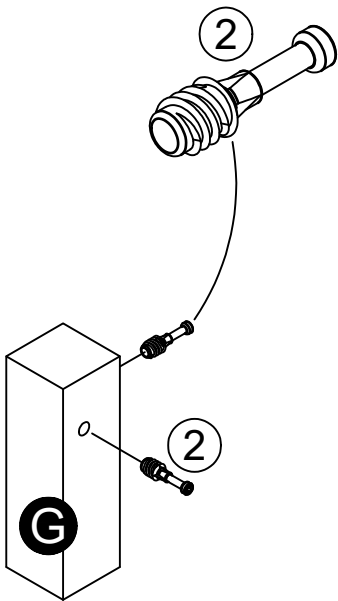
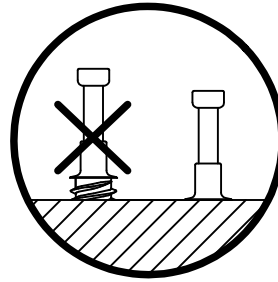
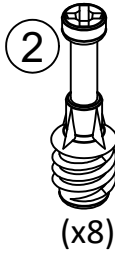
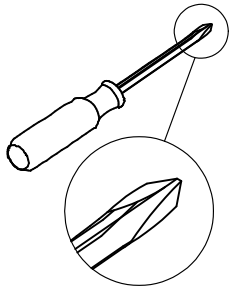

STEP 20

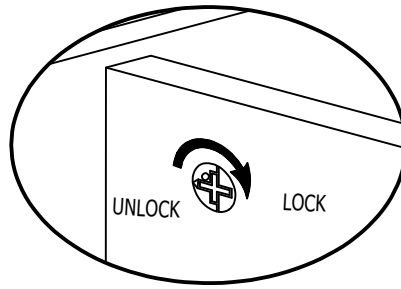
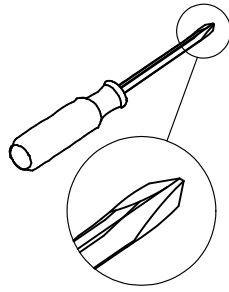

Top edges of both parts will be flush.

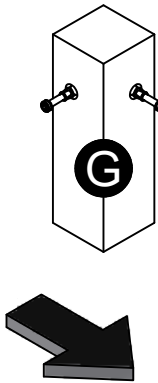

Top edges of both parts will be flush.

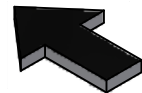
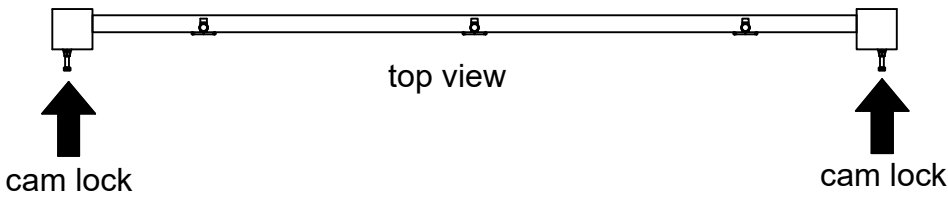

STEP 21

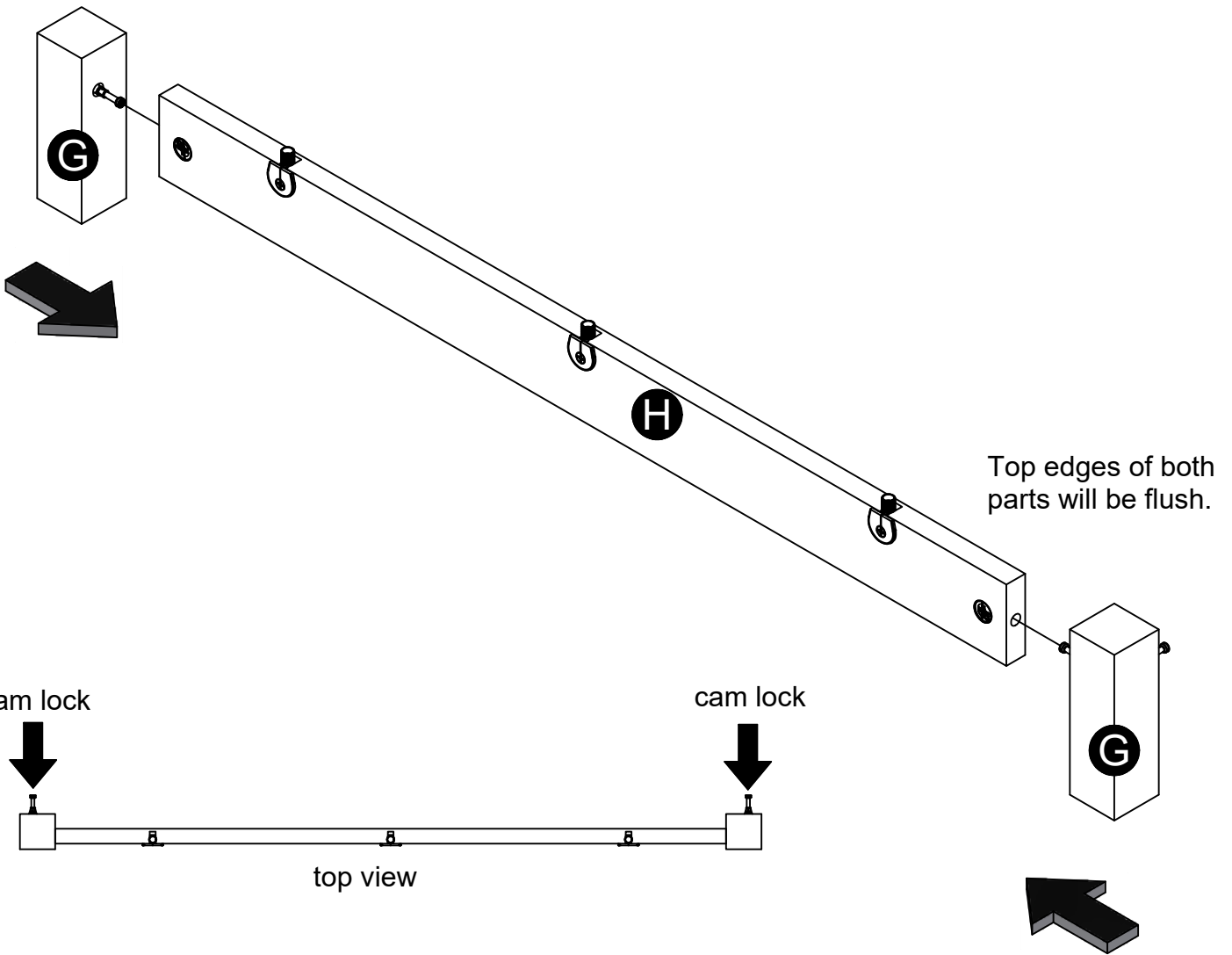
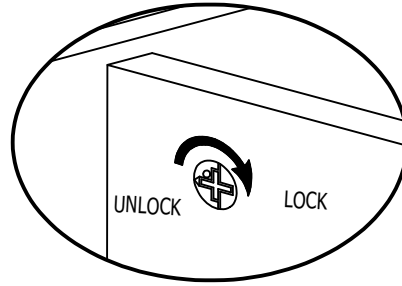
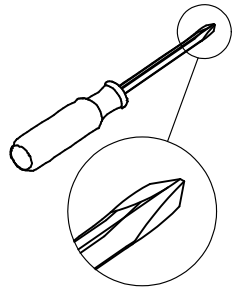

STEP 22

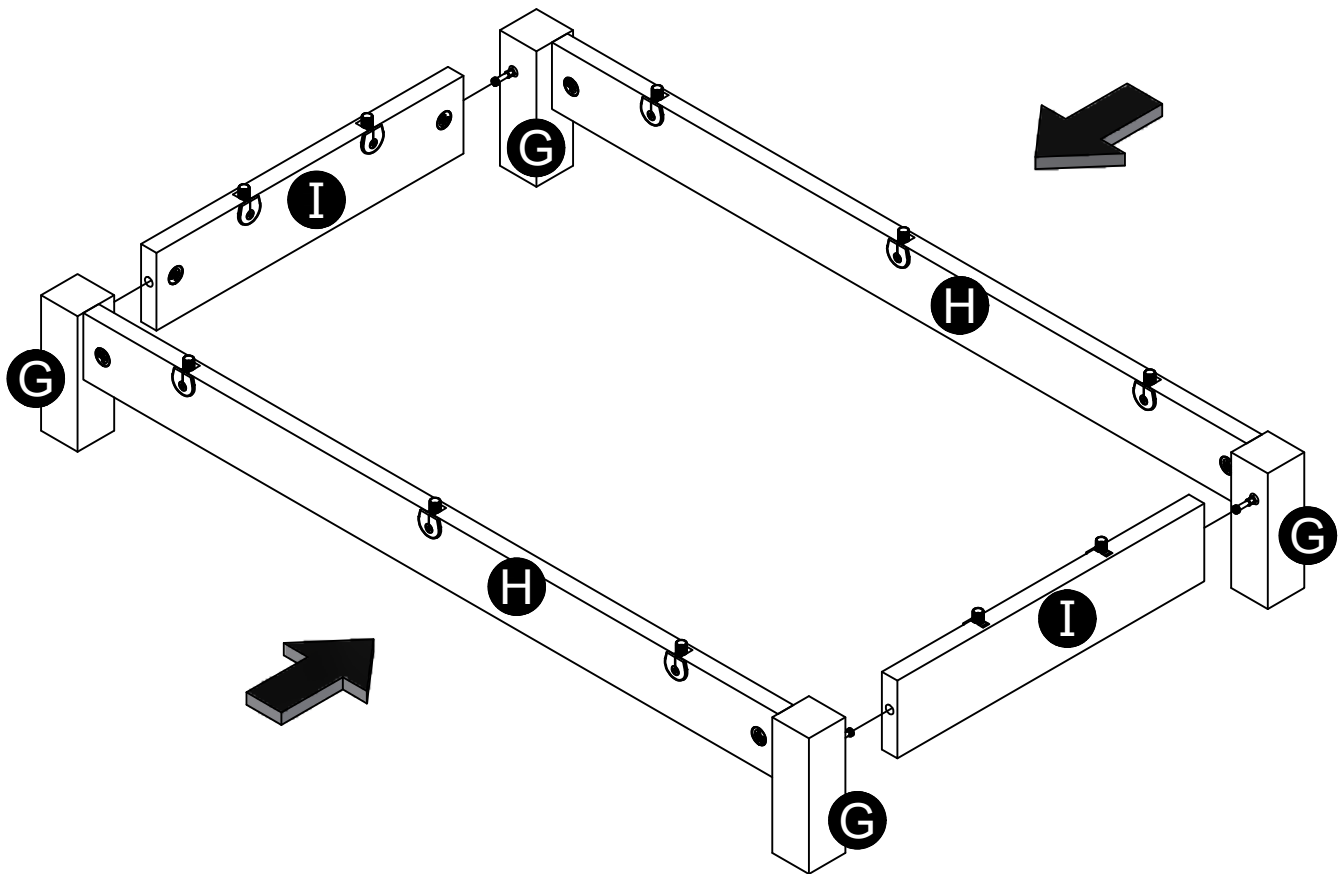
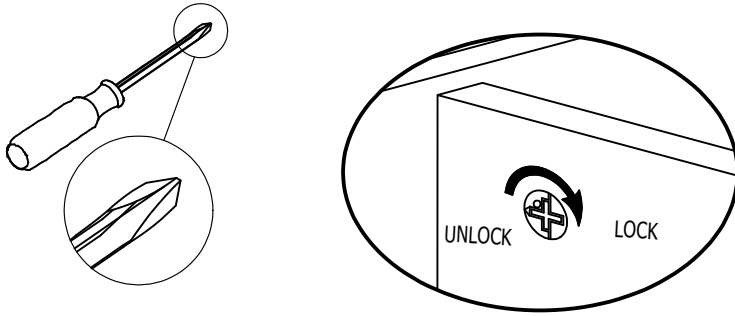

STEP 23

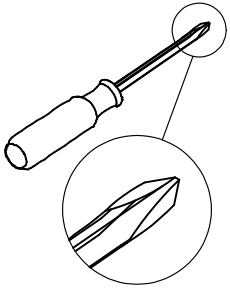

Turn screw clockwise to clamp parts together

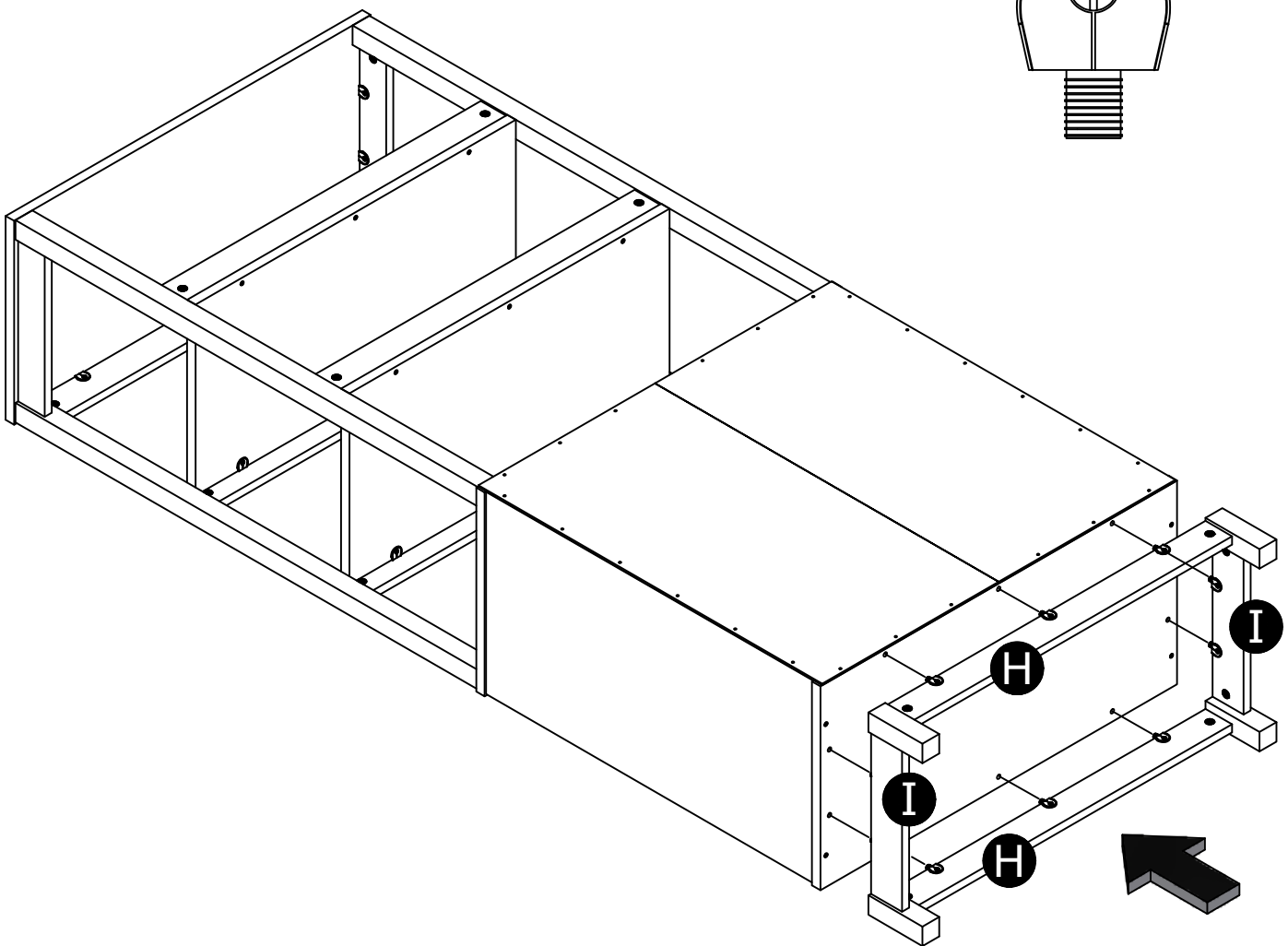
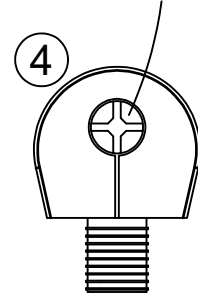

STEP 24

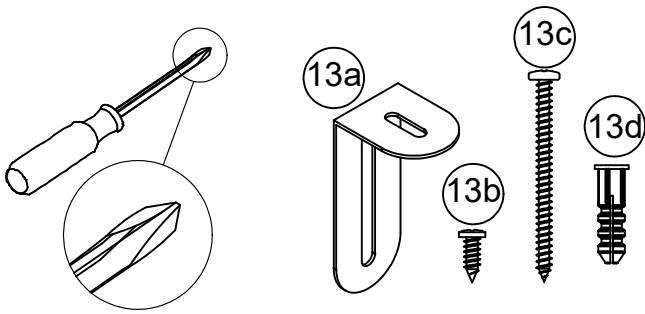

For Masonry, Concrete, or other wall materials:

Consult your local hardware store for appropriate anchors to securely attach the safety bracket.

IMPORTANT: THIS UNIT MUST BE SECURE TO THE WALL TO HELP PREVENT TIPOVER. FOLLOW THESE INSTRUCTIONS TO INSTALL THE ANTI-TIPPING SAFETY BRACKET PROVIDED WITH THIS PRODUCT.

WARNING

Serious or fatal crushing injuries can occur from furniture tipover.

To prevent tipover:

- * Install tipover restraint provided
- * Place heaviest items in the lowest drawers
- * Unless specifically designed to accommodate, do not set TVs or other heavy objects on the top of this product
- * Never allow children to climb or hang on drawers, door, or shelves
- * Never open more than one drawer at a time

Use of tipover restraints may only reduce, but not eliminate the risk of tipover

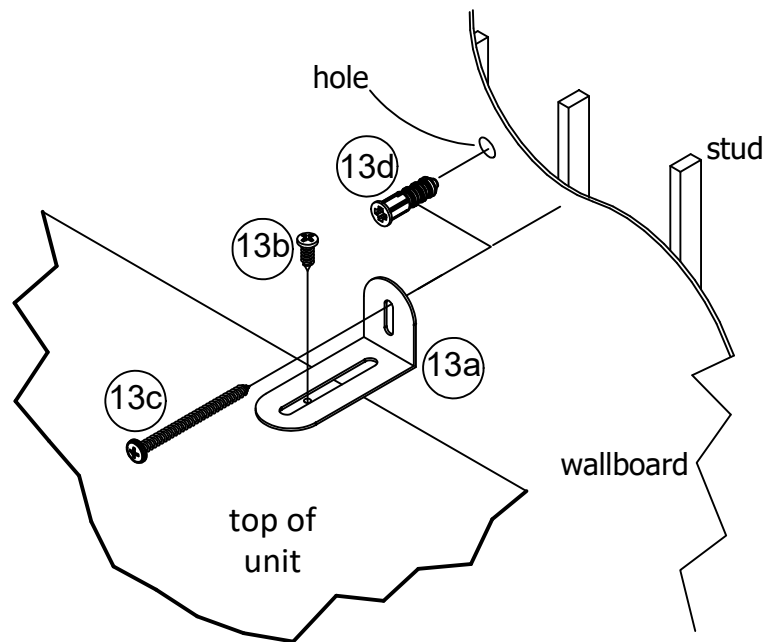

OPTION 1: Attachment into a wall stud (preferred method)

Using a stud finder, locate a stud in the wall. Place your unit against the wall, with the safety bracket aligned in this location. To make driving the screw easier, you can drill a 1/8" diameter pilot hole (3mm) through the safety bracket into the stud. Drive the screw through the safety bracket into the wall stud.

OPTION 2: Attachment into drywall

Locate your unit where desired against a wall and mark the wall through the safety bracket, then move your unit aside. Drill a 3/16" diameter hole (5mm) into the wallboard. Tap the wall anchor into the hole until it is flush. Move your unit into location and fasten the wall bracket to the wall anchor with the screw.

STEP 25

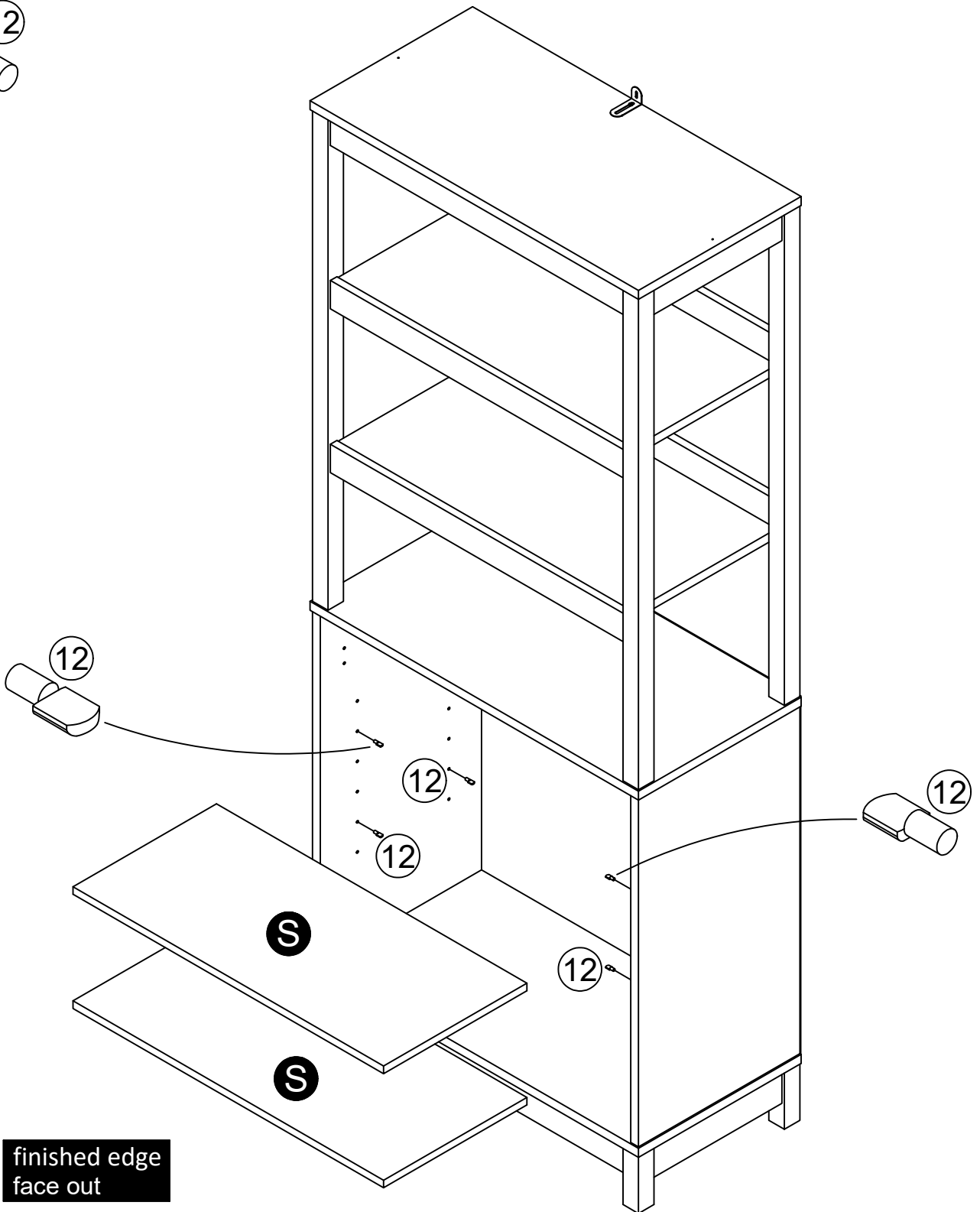
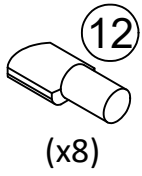

STEP 26

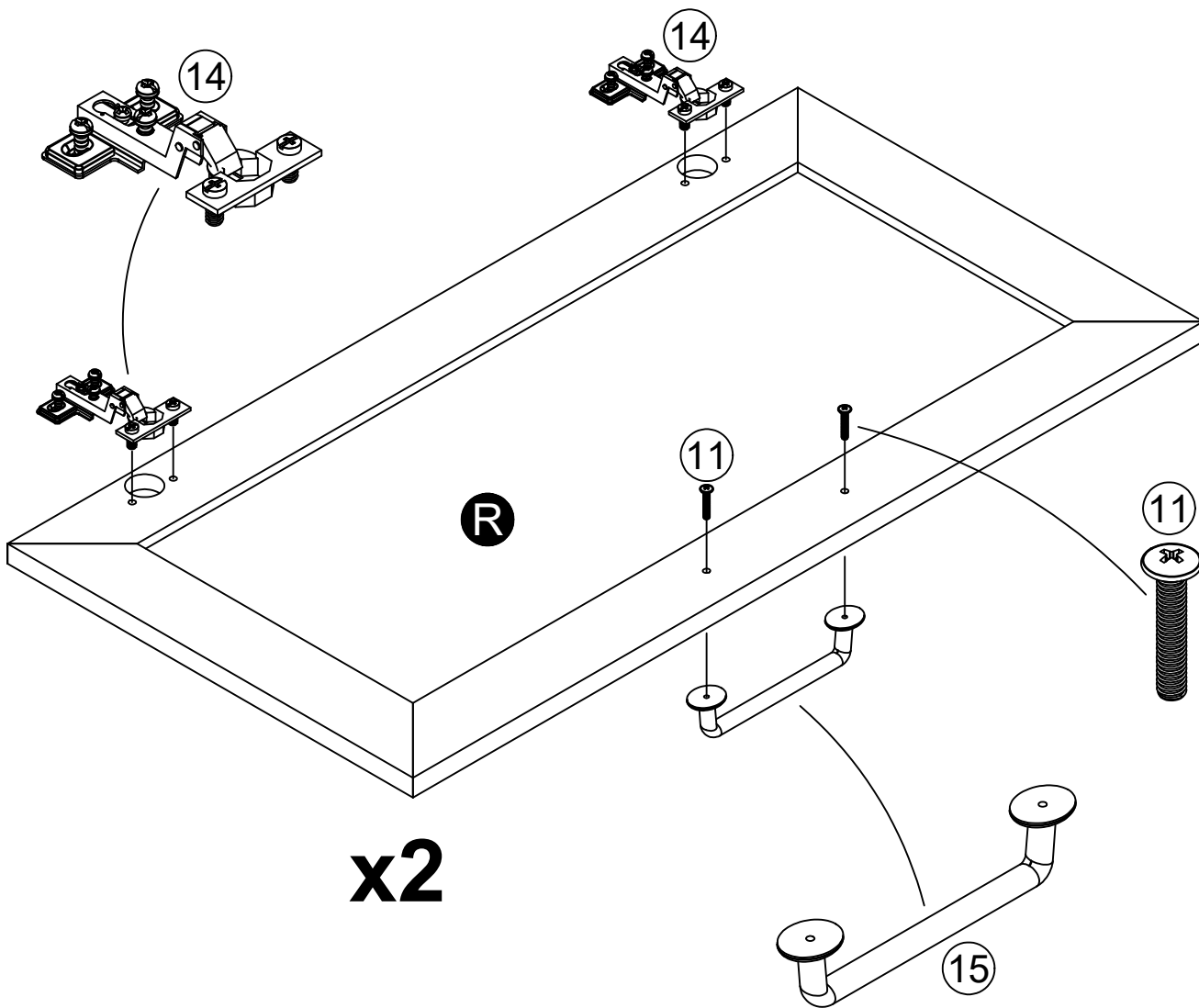
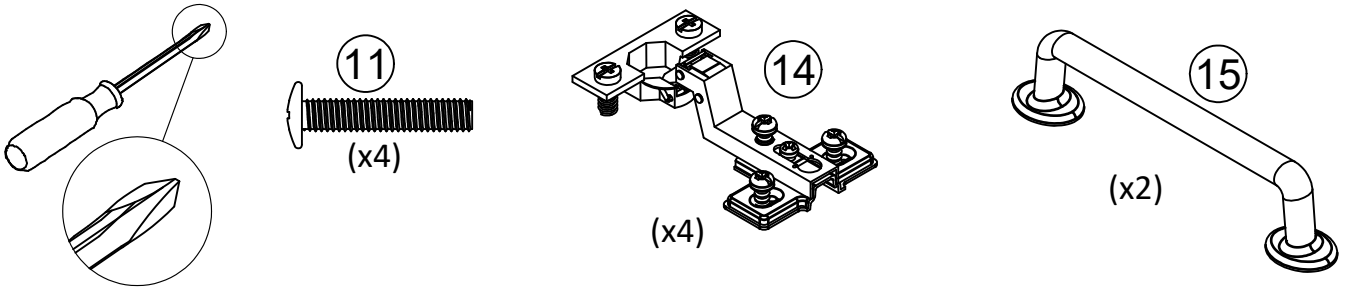

STEP 27

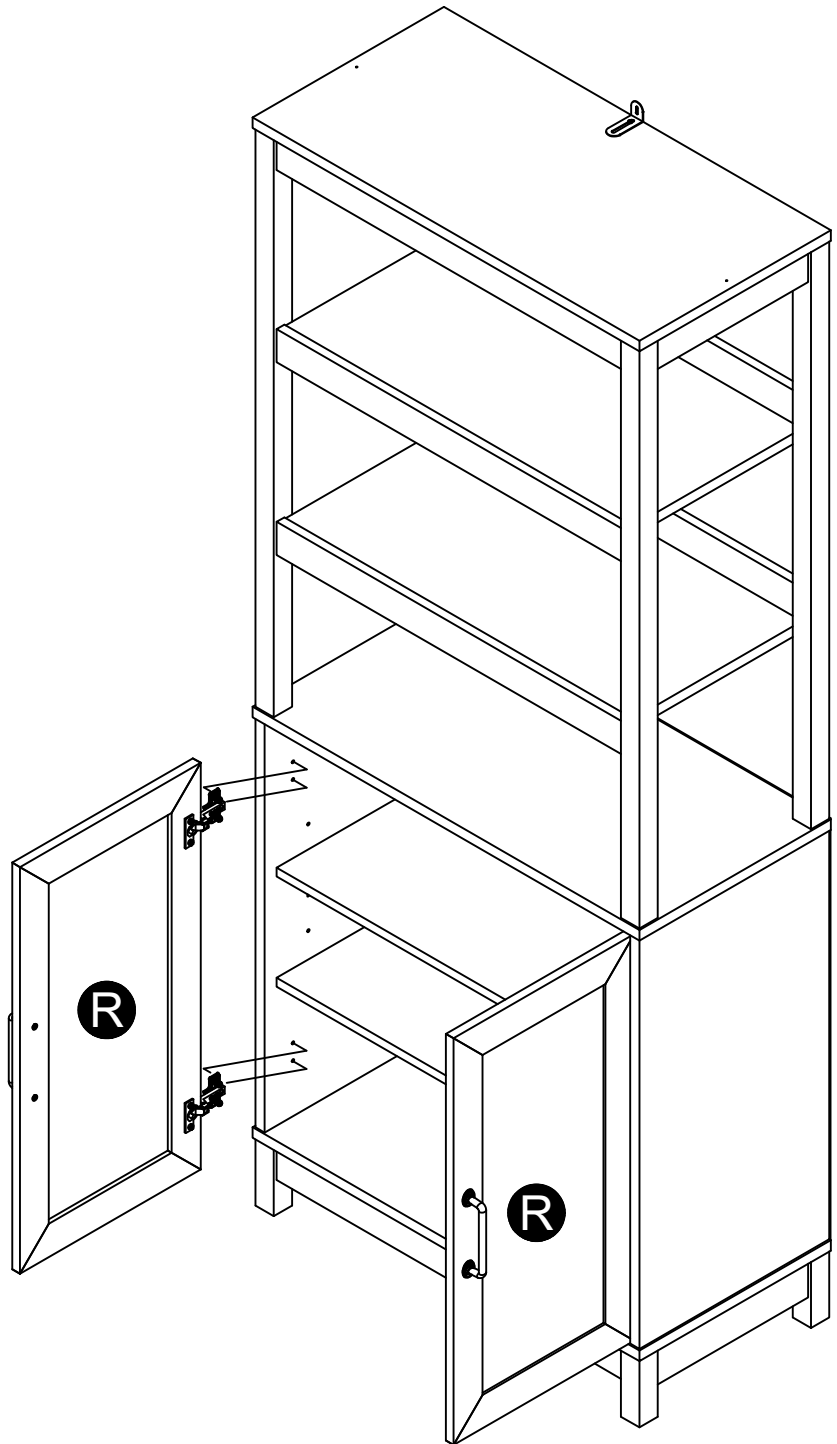
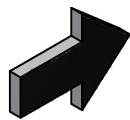
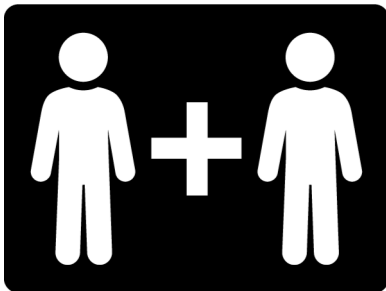
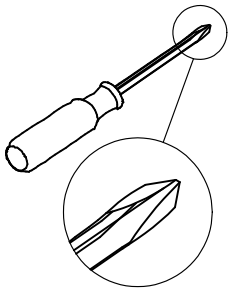

STEP 28

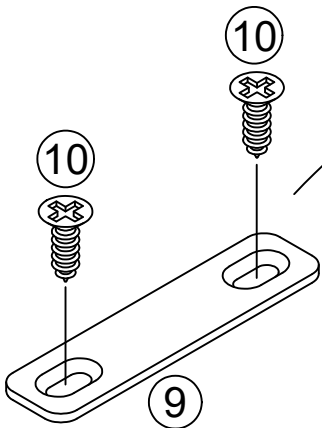
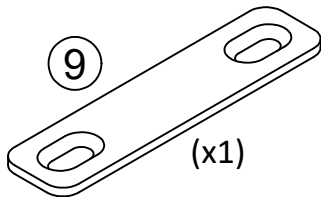
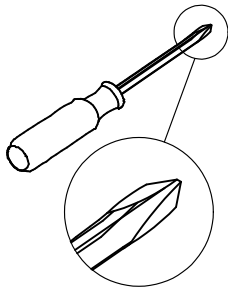

You can place two Cabinets side by side. Attach the two Cabinets together using the Straight Bracket (9).

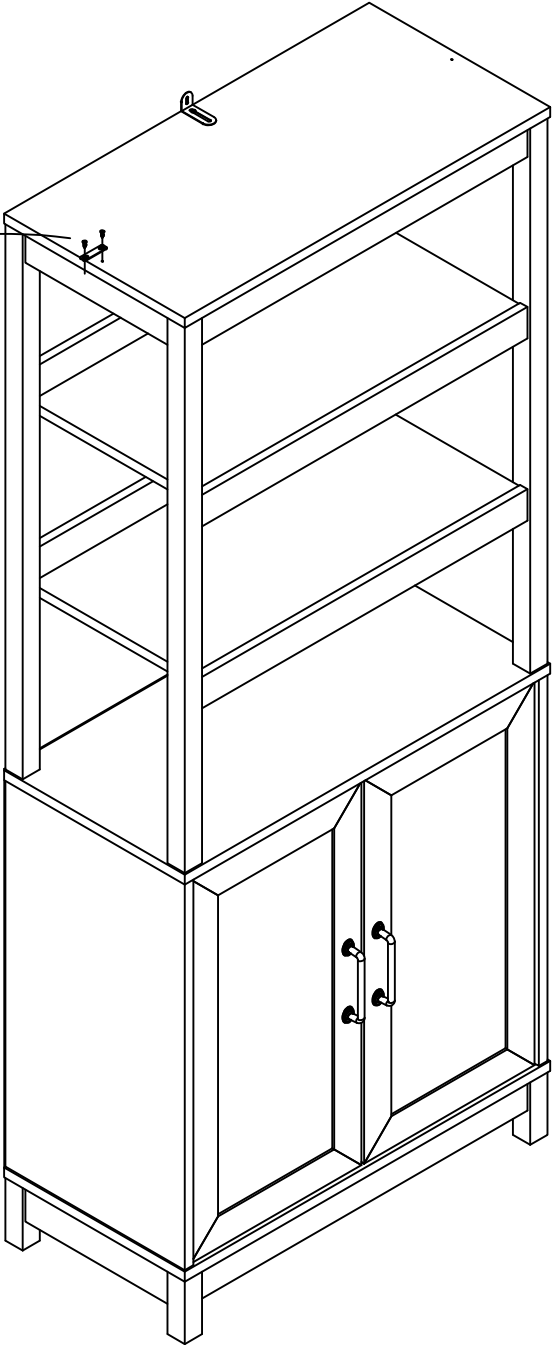

STEP 29

Door Adjustment

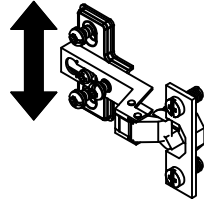
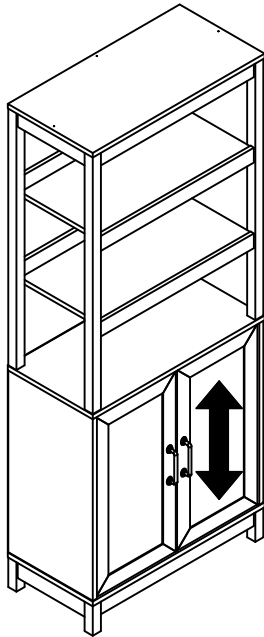
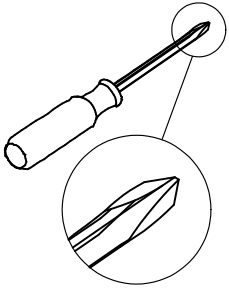

To adjust the vertical height:

Loosen the screws "A" on both hinges. They are usually in slotted holes which allows you to adjust up or down by a few mm. Then tighten back up.

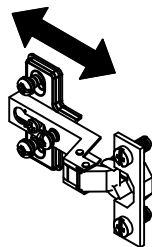
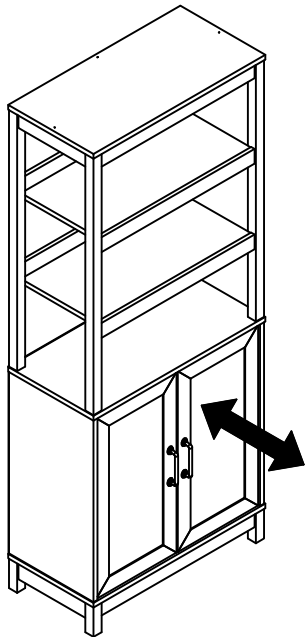
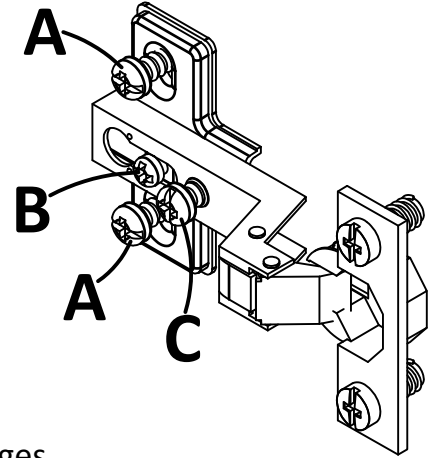

To adjust the depth:

Loosen the screw "B" and adjust door.

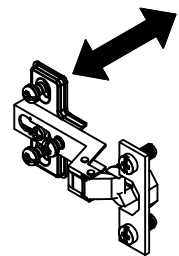
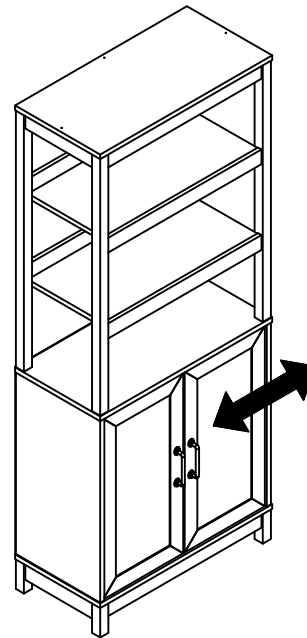

To adjust side to side:

Loosen the screw "C" on BOTH hinges and tighten "B" moves door outward. Loosen "B" and tighten "C" moves doors inward.

Maximum Loads

This unit has been designed to support the maximum loads shown. Exceeding these load limits could cause sagging, instability, product collapse, and/or serious injury.

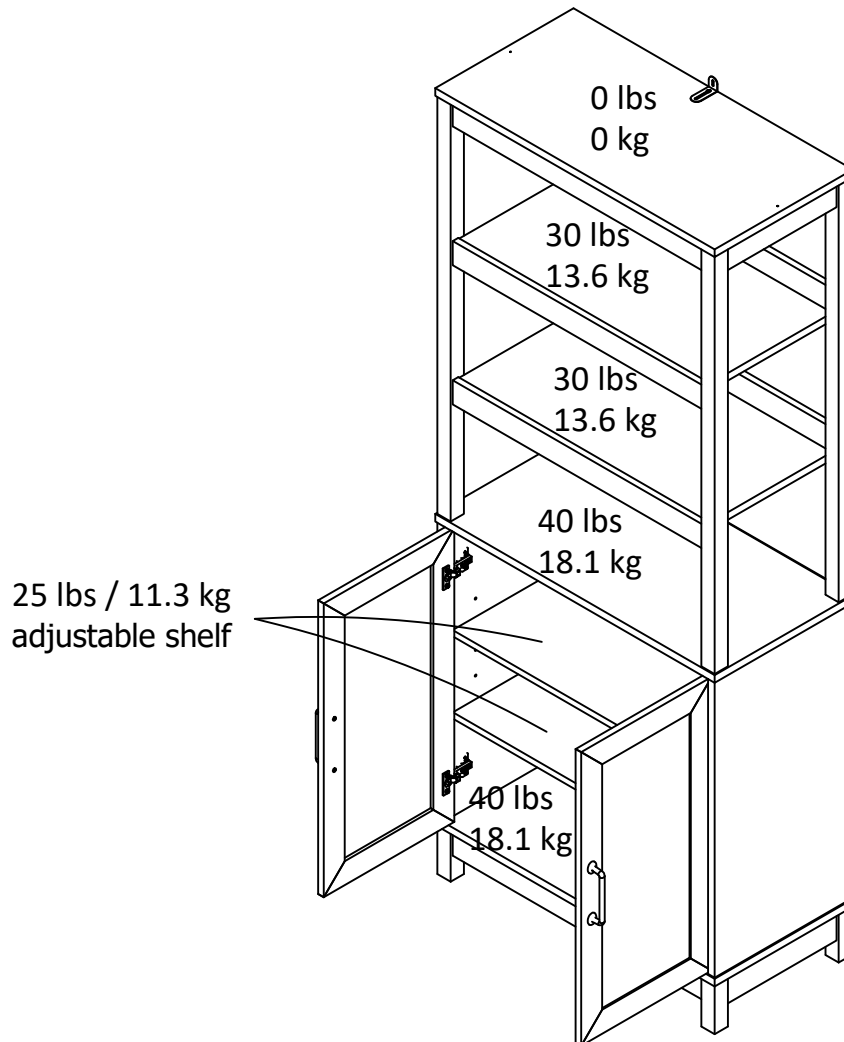

Warning: Risk of injury to persons - do not place a television on this furniture. This furniture is not approved for use with a television.

Certificate of Conformity

1. This certificate applies to the Dorel Home Furnishings, Inc. product identified by this instruction manual.
2. This certificate applies to compliance of this product with the CPSC Ban on Lead-Containing Paint (16 CFR 1303).
3. This product is distributed by: Dorel Home Furnishings, Inc.
410 East First Street South
Wright City, MO 63390
636-745-3351
4. Site of Manufacture: Tiffin OH
5. See front page of instruction manual for date of manufacture.

Register your product to receive the following:



- * New trend details - sneak peek on what's new
- * Surveys - have a voice within our community
- * Exclusive deals and discount codes
- * Quick and easy replacement part service

To register your product, visit ameriwoodhome.com

5 Star Rating



Visit your local retailer's website, rate your purchased product and leave us some feedback!

We would like to extend a big "Thank You" to all of our customers for taking the time to assemble this Ameriwood Home product, and to give us your valuable feedback.

*Thank
You!*

Cubierta Delantera

Este libro de instrucciones contiene información **IMPORTANTE** de seguridad. Por favor lea y manténgalo para referencia en el futuro.

No Regrese este producto! Comuníquese con nuestro amigoso equipo de servicio al cliente para obtener ayuda.

Llámenos al: 1-800-489-3351 (Gratis) Lunes - Viernes 9am - 5pm CST

Visitar: www.ameriwoodhome.com

PRECAUCION

Este mueble puede volcarse y causar graves heridas y/o muerte.

Anclar el mueble a un poste de madera en la pared (si esto se requiere).

No Permita que los niños monten el mueble.

Mantenga los artículos más pesados en los cajones de abajo.

Consejos Útiles (página 2)

- Abra su artículo en el área donde usted planea utilizarlo para evitar levantar y moverlo menos
- Identificar, ordenar y contar las piezas antes de intentar ensamblar
- Las clavijas de compresión se golpean con un martillo
- Las diapositivas están marcadas con una R (derecha) y L (izquierda) para la colocación correcta
- Asegúrese de que siempre este el punto localizado en la parte superior de bloqueador de leva este volteado hacia borde exterior
- Utilizar todos los clavos para el panel de atrás y distribuirlos por igual
- El panel de atrás debe utilizarse para asegurarse de que la unidad quede fija y firme
- No use químicas fuertes ni limpiadores abrasivos en este artículo
- Nunca empuje, tire ni arrastre los muebles

Antes de Que Empieces (página 3)

- Lea cuidadosamente cada paso y siga el orden correcto
- Separar y contar todas sus piezas y hardware
- Dése suficiente espacio para el proceso de ensamble
- Tenga las siguientes herramientas: destornillador de cabeza plana, #2 cabeza Phillips
Destornillador y martillo
- Precaución: Si usa un taladro electrónico o un destornillador eléctrico para atornillar, por favor asegúrese que deje de atornillar cuando el tornillo este apretado. Fallar hacer esto puede causar barrer el tornillo.

Sistema de fijar el bloqueo de leva (página 3)

Esta sistema de fijar el bloqueo de leva sera usado en todo el proceso ensamble.

Página 11 / 12

Los bordes superiores de todas las piezas quedarán nivelados.

Página 14 / 17 / 31

Gire el tornillo en sentido horario para sujetar las piezas.

Página 25

¡IMPORTANTE! EL PANEL TRASERO ES UNA PARTE ESTRUCTURAL DE ESTA UNIDAD Y DEBE INSTALARSE CORRECTAMENTE.

Con la ayuda de otra persona, gire la unidad sobre su parte frontal.

Fije el panel trasero como se muestra.

Clave directamente en los bordes desnudos.

Asegúrese de que la unidad esté a escuadra.

La distancia de esquina a esquina debe ser igual, tal y como se muestra.

Nivele el borde inferior del panel trasero con el borde inferior del fondo (D).

Página 28 / 29

Los bordes superiores de ambas partes quedarán nivelados.

Página 32

Para mampostería, concreto u otros materiales de pared:

Consulte con su ferretería local acerca de los anclajes apropiados para fijar de manera firme el soporte de seguridad.

IMPORTANTE: ESTA UNIDAD SE DEBE ASEGURAR A LA PARED PARA PREVENIR VOLCAMIENTOS. SIGA ESTAS INSTRUCCIONES PARA INSTALAR EL SOPORTE DE SEGURIDAD ANTIVOLCAMIENTO SUMINISTRADO CON ESTE PRODUCTO.

ADVERTENCIA

Pueden producirse lesiones graves o mortales por aplastamiento en caso de volcamiento del mueble.

Para prevenir volcamientos:

- * Instale el dispositivo de sujeción suministrado
- * Coloque los objetos más pesados en las gavetas más bajas
- * A menos que esté específicamente diseñado para tal fin, no coloque televisores u otros objetos pesados encima de este producto
- * Nunca permita que los niños se suban al mismo, ni que se cuelguen de las gavetas, la puerta o las repisas
- * Nunca abra más de una gaveta a la vez

El uso de dispositivos de sujeción podría solo reducir, mas no eliminar por completo el riesgo de volcamientos

OPCIÓN 1: Fijación en un entramado de la pared (método preferido)

Con la ayuda de un buscador de entramados, localice uno en la pared. Coloque su unidad contra la pared, con el soporte de seguridad alineado en dicha ubicación. Para facilitar el atornillado, puede taladrar un agujero piloto de 1/8" de diámetro (3 mm) a través del soporte de seguridad y dentro del entramado. Introduzca el tornillo a través del soporte de seguridad y dentro del entramado.

OPCIÓN 2: Fijación en paneles de yeso

Coloque la unidad en el lugar deseado contra una pared y marque dicha pared a través del soporte de seguridad; a continuación, haga a un lado la unidad. Taladre un agujero de 3/16" de diámetro (5mm) en el panel de yeso. Martille suavemente el anclaje de pared en el agujero hasta que quede al ras. Ponga la unidad en su sitio y fije el soporte de pared al anclaje con el tornillo.

Página 33

El borde pulido debe quedar hacia fuera.

Página 36

Puede colocar dos gabinetes uno al lado del otro. Una ambos gabinetes mediante el soporte recto (9).

Página 37

AJUSTE DE LA PUERTA

Para ajustar la altura vertical:

Afloje los tornillos "A" en ambas bisagras. Estos están usualmente en agujeros ranurados que le permiten ajustarlos hacia arriba o hacia abajo unos pocos milímetros. Luego vuelva a apretarlos.

Para ajustar la profundidad:

Afloje el tornillo "B" y ajuste la puerta.

Para ajustar de lado a lado:

Afloje el tornillo "C" en AMBAS bisagras y apriete el tornillo "B" para mover la puerta hacia afuera. Afloje el tornillo "B" y apriete el tornillo "C" para mover la puerta hacia dentro.

Página 38

CARGA MAXIMA

Esta unidad ha sido diseñada para soportar las cargas máximas indicadas. Exceder estos límites de carga podría provocar hundimiento, inestabilidad, colapso del producto y/o lesiones graves.

Advertencia: riesgo de lesiones a las personas, no ponga un televisor sobre este mueble. Este mueble no está homologado para su uso con un televisor.

Página 39

Registre su producto para recibir lo siguiente:

- * Detalles de nuevas tendencias - Vistazo a lo nuevo
- * Encuestas - alec su voz entre su comunidad
- * Códigos de ofertas y descuentos exclusivos
- * Fácil y rápido servicio de partes de remplace

Para registrar su producto, visite ameriwoodhome.com

Clasificación de 5 estrellas

Visite el sitio web de su tienda local, califique su comprado y denos sus comentarios!

Nos gustaría enviar un gran "Agradecimiento" a todos nuestros clientes por tomarse el tiempo de ensamblar este producto de Ameriwood Home, y por darnos sus valiosos comentarios.

Gracias

Couverture Avant

CE LIVRET D'INSTRUCTION CONTIENT DES INFORMATIONS **IMPORTANTES** SUR LA SÉCURITÉ. VEUILLEZ LIRE ET GARDER POUR UNE RÉFÉRENCE FUTURE

Ne retournez pas ce produit! Contactez notre équipe de service à la clientèle amicale d'abord pour obtenir de l'aide.

Appelez-nous: 1-800-489-3351 (sans frais) du Lundi au Vendredi de 9h à 17h Heure Centrale

Visitez: www.ameriwoodhome.com

ATTENTION

Le meuble peut basculer et causer des blessures graves ou la mort.

Ancrer le meuble à une planche murale dans le mur (si indiqué).

Ne laissez pas les enfants grimper sur le meuble.

Placez les articles lourds sur les étagères ou dans les tiroirs inférieurs.

Astuces Utiles (page 2)

-Ouvrez votre article dans la zone que vous prévoyez de le garder pour moins de levage lourd

-Identifier, trier et compter les pièces avant d'essayer d'assembler

-Les goujons de compression sont taraudés avec un Marteau

-Les glissières sont marquées d'un R (droit) et d'un L (gauche) pour un bon placement

-Assurez-vous toujours de faire face la pointe situé sur le haut de la Serrure de Came vers le bord extérieur

-Utiliser tous les clous fournis pour le panneau arrière et les répartir également

-Le panneau arrière doit être utilisé pour vous assurer que votre appareil est robuste

-N'utilisez pas de produits chimiques agressifs ou de nettoyeurs abrasifs sur cet appareil

-Ne jamais pousser, tirer, ou faire glisser votre meuble

Avant de Commencer (page 3)

-Lisez attentivement chaque étape et suivez le bon ordre

-Séparez et comptez toutes vos pièces et matériaux

-Donnez-vous suffisamment de place pour l'assemblage

-Avoir les outils suivants: tournevis à tête plate, #2 tournevis Phillips, et Marteau

-Attention: Si vous utilisez une perceuse électrique ou un tournevis électrique pour visser, veillez à ralentir et arrêter lorsque la vis est bien serrée. Le non-respect de cette consigne peut endommager la vis.

Système de Fixation de Came (page 3)

Ce Système de Fixation de Came sera utilisé tout au long de l'assemblage

Page 11/12

Les bords supérieurs de toutes les pièces seront alignés.

Page 14/17/31

Tourner la vis dans le sens des aiguilles d'une montre pour serrer les pièces ensemble.

Page 25

IMPORTANT! LE PANNEAU ARRIÈRE EST UN ÉLÉMENT STRUCTUREL DE L'APPAREIL ET DOIT ÊTRE INSTALLÉ CORRECTEMENT.

Avec l'aide d'une autre personne, retourner l'appareil sur le devant.

Fixer le panneau arrière comme indiqué.

Clouez directement dans les bords bruts.

Assurez-vous que notre unité est carrée.

La distance d'un coin à l'autre doit être égale, comme indiqué.

Alignez le bord inférieur du panneau arrière avec le bord inférieur du fond (D).

Page 28/29

Les bords supérieurs des deux parties doivent être alignés.

Page 32

Pour la maçonnerie, le béton ou d'autres matériaux muraux :

Demandez à votre quincaillerie locale de vous fournir les ancrages appropriés pour fixer solidement le support de sécurité.

IMPORTANT : CET APPAREIL DOIT ÊTRE FIXÉ AU MUR POUR ÉVITER QU'IL NE BASCULE. SUIVEZ CES INSTRUCTIONS POUR INSTALLER LE SUPPORT DE SÉCURITÉ ANTI-BASCULEMENT FOURNI AVEC CE PRODUIT.

AVERTISSEMENT

Le basculement d'un meuble peut entraîner des blessures graves ou mortelles par écrasement.

Pour éviter le basculement :

- * Installer les dispositifs de retenue en cas de basculement prévus
- * Placer les objets les plus lourds dans les tiroirs les plus bas.
- * Ne pas poser de téléviseur ou d'autres objets lourds sur le dessus de ce produit, sauf s'il a été spécialement conçu à cet effet.
- * Ne jamais laisser les enfants grimper ou s'accrocher aux tiroirs, aux portes ou aux étagères.
- * Ne jamais ouvrir plus d'un tiroir à la fois.

L'utilisation de dispositifs de retenue en cas de basculement ne peut que réduire, mais pas éliminer, le risque de basculement.

OPTION 1 : Fixation dans un montant mural (méthode préférée)

À l'aide d'un détecteur de montants, repérez un montant dans le mur. Placez votre appareil contre le mur, avec le support de sécurité aligné à cet endroit. Pour faciliter l'enfoncement de la vis, vous pouvez percer un avant-trou de 3 mm de diamètre à travers le support de sécurité dans le montant. Enfoncez la vis à travers le support de sécurité dans le montant du mur.

OPTION 2 : Fixation dans la cloison sèche

Placez votre appareil à l'endroit souhaité contre un mur et marquez le mur à travers le support de sécurité, puis mettez votre appareil de côté. Percez un trou de 3/16 pouce (5 mm) de diamètre dans le panneau mural. Tapez la cheville dans le trou jusqu'à ce qu'elle soit à fleur. Mettez votre appareil en place et fixez le support mural à l'ancrage mural à l'aide de la vis.

Page 33

Le bord final est orienté vers l'extérieur.

Page 36

Vous pouvez placer deux armoires côte à côte. Fixez les deux armoires ensemble à l'aide du support droit (9).

Page 37

AJUSTEMENT DE LA PORTE

Pour régler la hauteur verticale :

Desserrez les vis « A » des deux charnières. Elles se trouvent généralement dans des trous oblongs, ce qui vous permet de les ajuster de quelques millimètres vers le haut ou vers le bas. Resserrez ensuite.

Pour régler la profondeur :

Desserrez la vis « B » et ajustez la porte.

Pour le réglage latéral :

Desserrez la vis « C » sur les DEUX charnières et serrer « B » déplace la porte vers l'extérieur. Desserrez la vis « B » et serrer la vis « C » déplace la porte vers l'intérieur.

Page 38

CHARGES MAXIMALES

Cet appareil a été conçu pour supporter les charges maximales indiquées. Le dépassement de ces limites de charge peut entraîner un affaissement, une instabilité, un effondrement du produit et/ou des blessures graves.

Avertissement : Risque de blessure pour les personnes -- ne placez pas de téléviseur sur ce meuble. Ce meuble n'est pas homologué pour recevoir un téléviseur.

Page 39

Enregistrez votre produit pour recevoir les éléments suivantes:

- * Détails sur les nouvelles tendances - un aperçu sur les nouveautés
- * Sondages - avoir une voix au sein de notre communauté
- * Offres exclusives et codes promo
- * Service de pièces de rechange rapide et facile

Pour enregistrer votre produit, visitez ameriwoodhome.com

5 Étoiles

Visitez le site Web de votre détaillant local, évaluez votre produit acheté et laissez-nous quelques commentaires !

Nous tenons à offrir un grand "Merci" à tous nos clients pour avoir pris le temps d'assembler ce produit "Ameriwood Home", et de nous donner vos commentaires précieux.

Merci